

**SAFETY.CAT.COM™**

# **MAINTENANCE INTERVALS**

Operation and Maintenance  
Manual Excerpt

# Operation & Maintenance Manual

---

## **140H & 160H Motor Graders NA Version**

---

**2ZK1-UP  
3GM1-UP  
9EJ1-UP  
9TN1-UP  
9ZN1-UP**



## Maintenance Intervals

### When Required

Engine Air Inlet System — Service filters	114
Ether Starting Aid (If Equipped) — Replace cylinder	116
Fuel System — Service when loss of power	159
Fuses and Circuit Breakers — Replace/reset	117
Windshield Wipers and Washer — Inspect/Fill reservoir	119
Cutting Edge and End Bits — Replace if damaged	120
Ripper Teeth (If Equipped) — Replace if damaged	120
Scarifier Teeth (If Equipped) — Replace if damaged	121
Moldboard Wear Strip — Replace if damaged	122
Circle Drive Housing — Check oil level	123
Drawbar Ball and Socket — Check/Adjust	123
Blade Circle — Check/Adjust	124
Blade Lift Cylinder Sockets — Adjust/Replace	127
Centershift Cylinder Sockets — Adjust/Replace	127
Blade Accumulator (If Equipped) — Change	128
Steering Accumulator — Charge	128
Filter Inspection — Inspect used oil filter for debris	129
Cooling System — Replace coolant and thermostat	170

### Every 10 Service Hours or Daily

Engine Crankcase Oil — Check the oil level	130
Radiator — Check coolant level	131
Hydraulic Tank Oil — Check the oil level	131
Circle Pinion Teeth — Lubricate	132
Circle Top — Lubricate	132
Walk-Around Inspection — Inspect machine	133
Air Reservoir — Drain moisture and sediment	134
Fuel Tank — Drain moisture and sediment	137
Seat Belt — Inspect	137
Brakes, Indicators and Gauges — Test	138
Backup Alarm — Test	138

### Every 50 Service Hours or Weekly \*

Cab Air System (If Equipped) — Clean filters	139
Axle Oscillation Bearings — Lubricate fittings	140
Leaning Wheel Bearings — Lubricate fittings	141
Leaning Bar Bearings — Lubricate fittings	141
Leaning Wheel Cylinder Bearings — Lubricate fittings	142
King Pin Bearings — Lubricate fittings	142
Articulation Bearings — Lubricate fittings	143
Drawbar Draft Ball — Lubricate fittings	143
Ripper (If Equipped) — Lubricate fitting	144
Scarifier (If Equipped) — Lubricate fittings	144
Tires — Check inflation pressure	145

### Every 250 Service Hours or Monthly \*

Engine Oil and Filter — Change. If the sulfur content in the fuel is greater than 1.5% by weight, use an oil with a TBN of 30 and reduce the oil change interval by one half	146
Cooling System — Add coolant additive	147
Centershift Cylinder — Lubricate fittings	147
Blade Lift Cylinders — Lubricate fittings	148
Transmission and Differential Housing — Check	148
Tandem Drive Housings — Check	149
Brakes — Test	149
Fan and Alternator Belts — Inspect/adjust	151
Air Conditioner (If Equipped) — Test	152
Air Dryer (If Equipped) — Drain moisture	154
Batteries — Inspect	154

**Every 500 Service Hours or 3 Months \***

Transmission and Differential Oil  
Filter and Screens — Change/Clean .....156  
Hydraulic System — Change filter .....158  
Fuel System — Change filter/clean screen .....159  
Fuel Tank Cap and Fill Screen — Clean .....160  
Engine Crankcase Breather — Clean .....161  
Hydraulic Pump Driveshaft —  
Lubricate fittings .....162  
Front Wheel Spindle Bearings —  
Check the oil level .....162

**Every 1000 Service Hours or 6 Months \***

Transmission and Differential Oil —  
Change oil and breather .....163  
Rollover Protective Structure (ROPS) —  
Inspect .....164  
Air Dryer (If Equipped) — Change dessicant .....165

**Every 2000 Service Hours or 1 Year \***

Hydraulic System Oil — Change the oil .....166  
Tandem Drive Housing Oil — Change the oil ....167  
Circle Drive Housing — Change the oil .....168  
Engine Valve Lash — Adjust .....169  
Engine Valve Rotators — Check .....169

**Every 3000 Service Hours or 2 Years \***

Cooling System Coolant — Change .....170

\* First Perform Previous Service Hours Items

## When Required

*You must read and understand the warnings and instructions contained in the Safety Section of this manual, before performing any operation or maintenance procedures.*

### Engine Air Inlet System

#### Clean the Air Inlet

---

##### NOTICE

Service the air cleaner only with the engine stopped. Engine damage could result.

---



The precleaner bowl is located at the center rear of the machine.

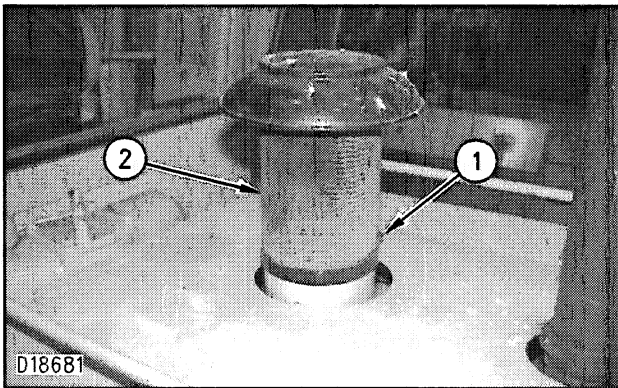

**1.** Loosen the clamp (1) at the bottom of the precleaner (2).

- 2.** Remove the precleaner (2) and inspect the precleaner tube openings for dirt and debris. Clean the tubes if necessary.
- 3.** Install the precleaner (2) and tighten the clamp (1).

#### Service the Filter Elements

---

##### NOTICE

Service the air cleaner only with the engine stopped. Engine damage could result.

---

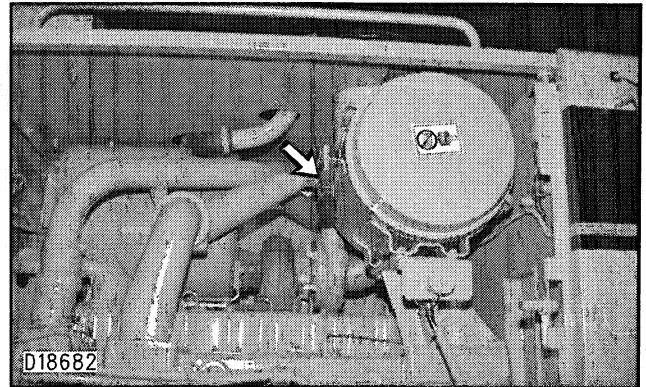

Service the air cleaner if the yellow piston in the filter element indicator moves into the red zone with the engine running at high idle. Stop the engine.

#### Service the Primary Element



**1.** Open the access door.

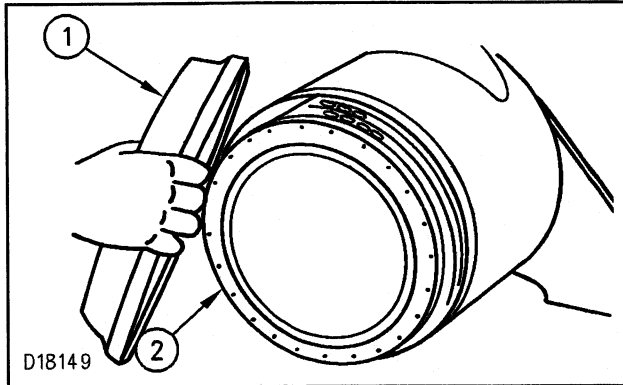

2. Remove the air cleaner cover (1).
3. Remove the primary filter element (2) from the air cleaner housing.

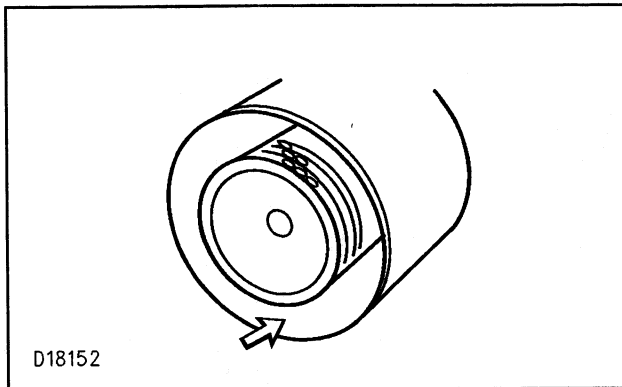

4. Clean the inside of the air cleaner housing.
5. Clean and inspect the primary element. See Cleaning Primary Elements.
6. Install a clean primary element.
7. Clean and install the cover.
8. Close the access door.
9. Reset the filter element indicator.

If the yellow piston in the filter element indicator moves into the red zone after starting the engine, or the exhaust smoke is still black after installation of a clean primary filter element, install a new primary filter element. If the piston remains in the red zone after resetting and installing a new primary filter element, replace the secondary element.

Replace the primary element after it has been cleaned a maximum of six times. Replace the primary element once a year even though it has not been cleaned six times.

### Change the Secondary Element

#### NOTICE

Always replace the secondary filter element. Never attempt to reuse it by cleaning.

The secondary filter element should be replaced at the time the primary element is serviced for the third time.

The secondary filter element should also be replaced if the yellow piston in the filter element indicator enters the red zone after installation of a clean primary element, or if the exhaust smoke is still black.

1. Open the access door.
2. Remove the housing cover and the primary element.

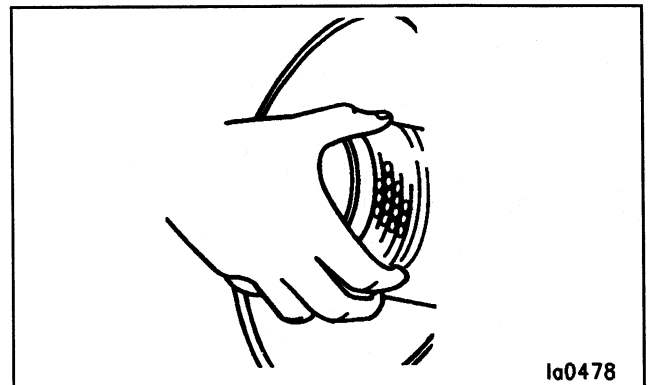

3. Cover the air inlet opening. Clean the inside of the air cleaner housing.
4. Uncover the air inlet opening. Install a new secondary element.
5. Install the primary element and cover.
6. Close the access door.
7. Reset the filter element indicator.

## Cleaning Primary Elements

### NOTICE

Do not clean the filter elements by bumping or tapping them. Do not use filter elements with damaged pleats, gaskets or seals. Engine damage can result.

Make sure the cleaned filter elements are completely dry before installing into the filter housing. Water remaining in the elements can cause false indications of contamination in Scheduled Oil Sampling test results.

Filter elements can be cleaned with pressure air — 205 kPa (30 psi) maximum, pressure water — 280 kPa (40 psi) maximum, or detergent washing.

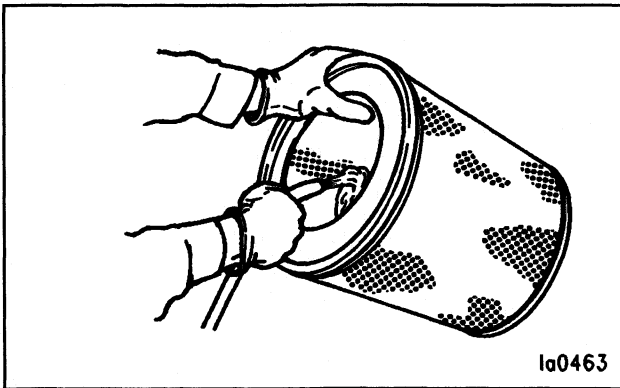

1. Direct air or water along the pleats inside and outside of filter element.

The element can be washed in warm water and nonsudsing household detergent. Rinse inside and outside the pleats and air dry fully.

2. Inspect the filter elements after cleaning. Do not use a filter element with damaged pleats, gaskets or seals.
3. Wrap and store the clean filter elements in a clean, dry place.

## Ether Starting Aid (If Equipped)

### Installing the Cylinder



1. Open the left access door on the rear of the machine. The ether cylinder is mounted on the left side of the compartment.

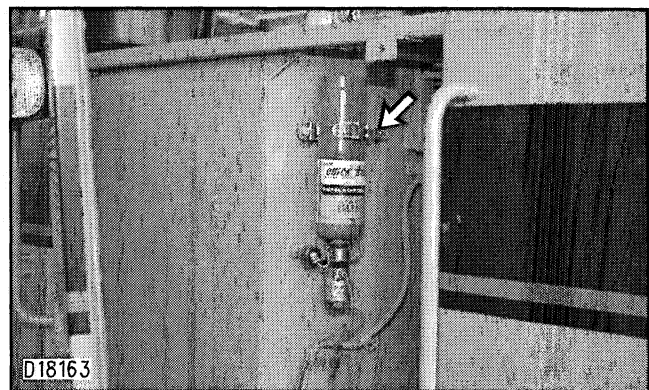

2. Loosen the cylinder retaining clamp. Remove the empty ether cylinder.
3. Remove the used gasket. Install the new gasket provided with each new cylinder.
4. Install the new cylinder. Tighten the cylinder hand tight. Tighten the cylinder clamp securely.
5. Close the access door.

## Fuses and Circuit Breakers

### Replace Fuses

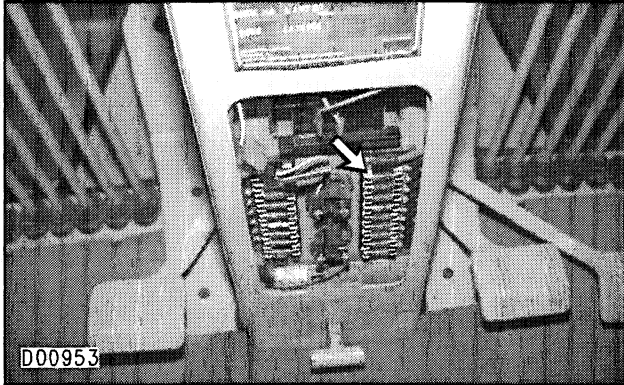

 **Fuses** — Protect the electrical system from damage caused by overloaded circuits. Change a fuse if the element separates. If the element of a new fuse separates, have the circuit checked and repaired.

#### NOTICE

Replace the fuses with the same type and size only. Otherwise, electrical damage can result.

If it is necessary to replace fuses frequently, an electrical problem may exist. Contact your Caterpillar dealer.

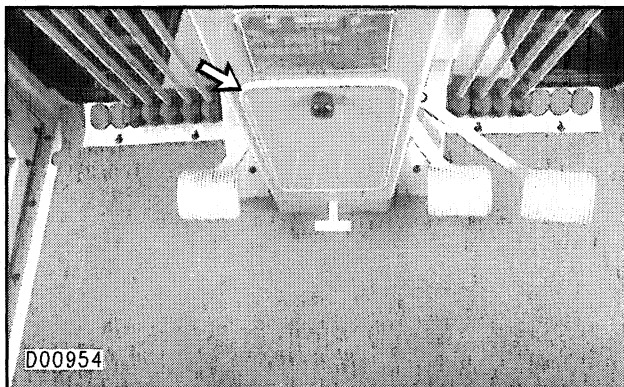

The fuse panels are located in the base of the steering column and on the wiper control box at the operator's right.

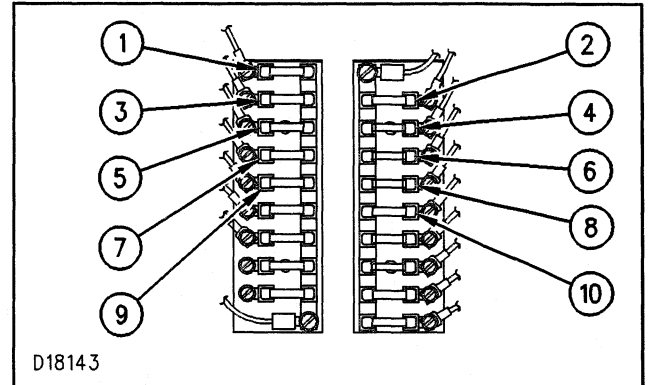

Tail Lights (1) — 10 amps.



Gauges (2) — 10 amps.



Key Switch (3) — 10 amps.



Rear Flood Lights (4) — 10 amps.



Shutdown Control (5) — 10 amps.



Air Dryer (6) — 20 amps.



Horn (7) — 10 amps.



Heating & Air Conditioning (8) — 15 amps.









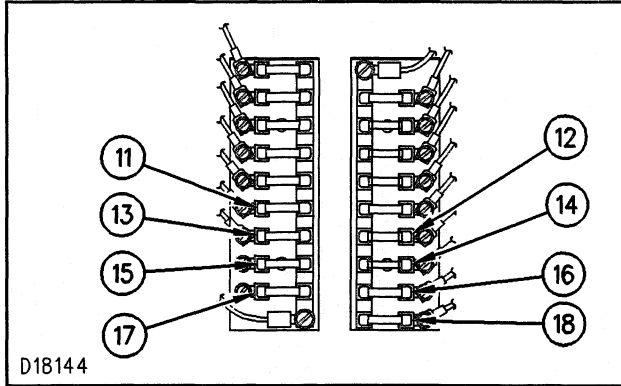

Stop Lights (9) — 10 amps.







Transmission Control (10) — 10 amps.

118  
 Maintenance Section  
 When Required

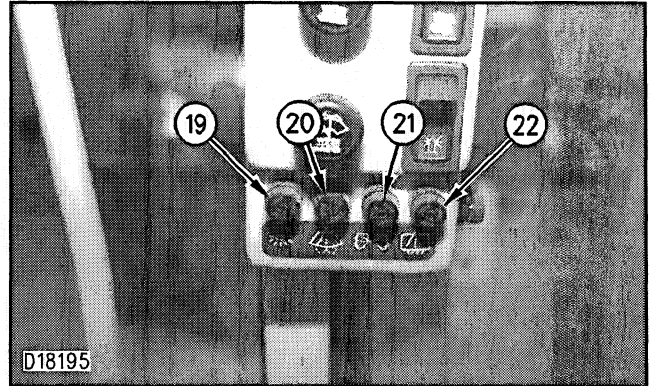



-  Secondary Steering (11) — 10 amps.
-  Secondary Steering (12) — 10 amps.
-  Turn Signals (13) — 10 amps.
-  Blade Flood Lights (14) — 10 amps.
-  Spare (15) — amps.
-  Differential Lock (16) — 10 amps.
-  Spare (17) — amps.
-  Blade Control (18) — 10 amps.

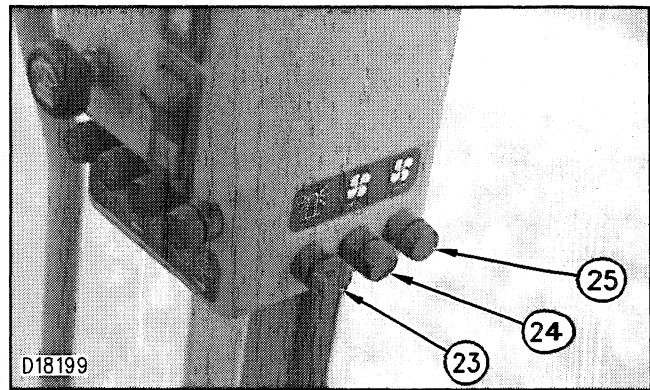

-  Dome Lamp (19) — 10 amps.
-  Front Lower Wiper and Washer (20) — 10 amps.
-  Front Upper Wiper and Washer (21) — 10 amps.
-  Rear Wiper and Washer (22) — 10 amps.



-  Beacon (23) — 10 amps.
-  Front Defrost Fan (24) — 10 amps.
-  Rear Defrost Fan (25) — 10 amps.



## Reset Circuit Breakers



**Circuit Breaker Reset** — Push the button in to reset the circuit breakers. If working properly, the button will stay depressed. If the button does not stay in, or comes out shortly after being reset, have appropriate electrical circuit checked.

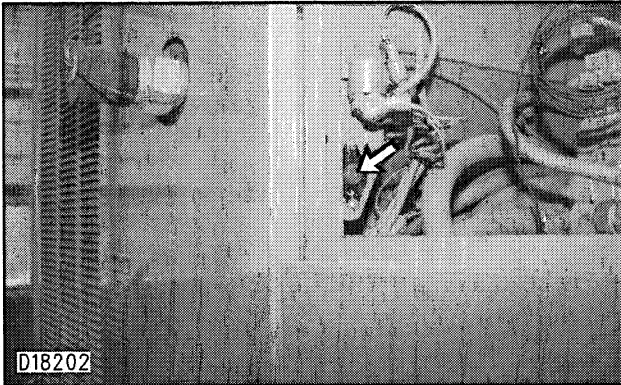

The Alternator (Main) circuit breaker is located at the rear right of the engine compartment.



**Alternator (Main)** — 60 amps or 80 amps depending on the alternator that is on the machine.

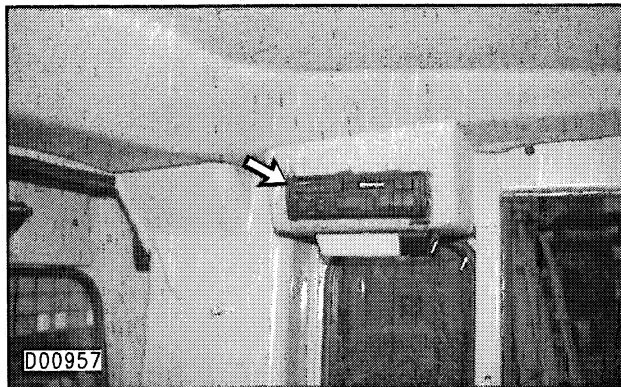

The Radio circuit breaker (if equipped) is located at the upper left rear of the cab.



**Radio — Entertainment (If Equipped)** — 5 amps



**Radio — Communications (If Equipped)** — 25 amps

## Windshield Wipers and Washer

### Inspect/Replace



Inspect the front upper, front lower and rear windshield wiper blades. Replace if they are worn or damaged, or if streaking occurs.

### Fill Reservoir

#### NOTICE

When operating in freezing temperatures, use Caterpillar nonfreezing window washer solvent or equivalent. System damage can result from freezing.

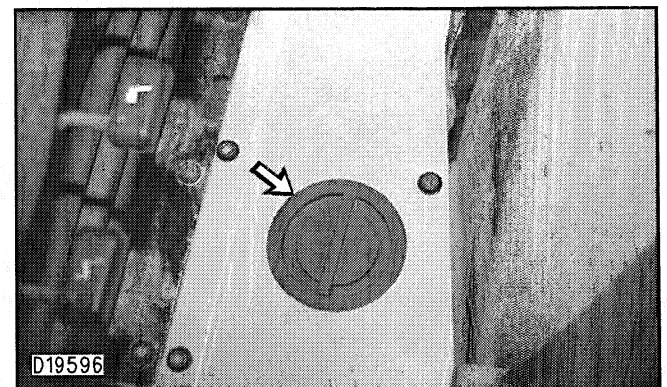

The windshield washer bottle is located in the seat support the left of the operator's seat. The bottle can be filled through the filler opening located in the floor of the operator compartment.



## Cutting Edge and End Bits

Replace if Damaged

### **⚠ WARNING**

Personal injury or death can result from the blade falling.

**Block the blade before changing blade tips.**

Change the cutting edge and/or end bits if damaged or worn excessively.

1. Block the moldboard brackets. Do not block the moldboard any higher than necessary to remove the end bits and cutting edge.

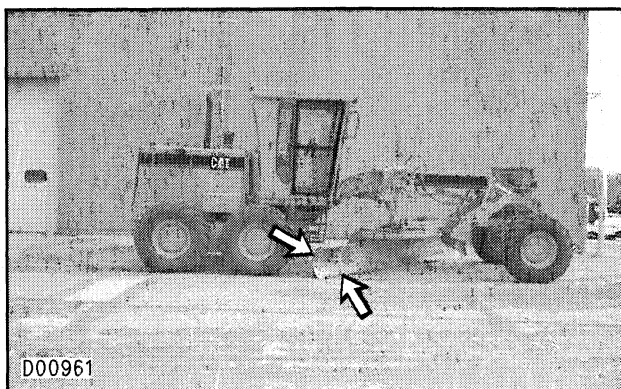

2. Remove cutting edge and end bits.
3. Install a new cutting edge and end bits.
4. Raise the blade and remove blocking.

## Ripper Teeth (If Equipped)

Replace if Damaged

### **⚠ WARNING**

Personal injury or death can result from a falling ripper.

**Block the ripper before changing teeth.**

### **⚠ WARNING**

Retainer pins, when struck with force, can fly out and cause injury to nearby people.

**Make sure the area is clear of people when driving retainer pins.**

**To avoid injury to your eyes, wear protective glasses when striking a retainer pin.**

Change the ripper teeth if damaged or worn excessively.

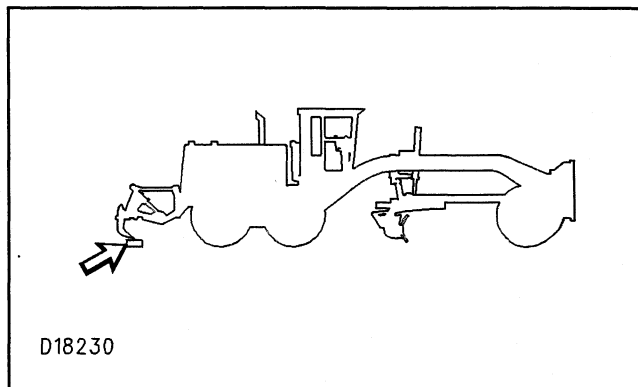

1. Block the ripper. Do not block the ripper any higher than necessary to remove the teeth.

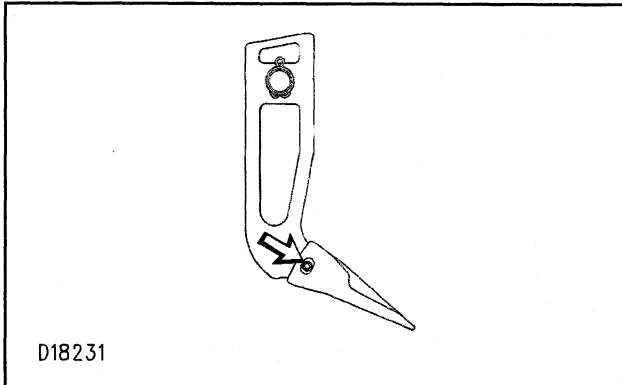

2. Drive the pin out of the tooth from the retainer side of the tooth. Remove the tooth and the retainer.
3. Clean the adapter, pin and retainer. Install the retainer in the groove.
4. Install the new tooth over the retainer.
5. Drive the pin through the retainer, adapter, and tooth from the side opposite of the retainer.
6. Repeat for additional teeth replacement.
7. Raise the ripper and remove blocking.

## Scarifier Teeth (If Equipped)

Replace if Damaged

### **⚠ WARNING**

Personal injury or death can result from falling front mounted scarifier.

Block the front mounted scarifier before changing teeth.

### **⚠ WARNING**

Retainer pins, when struck with force, can fly out and cause injury to nearby people.

Make sure the area is clear of people when driving retainer pins.

To avoid injury to your eyes, wear protective glasses when striking a retainer pin.

Change the front mounted scarifier teeth if damaged or worn excessively.

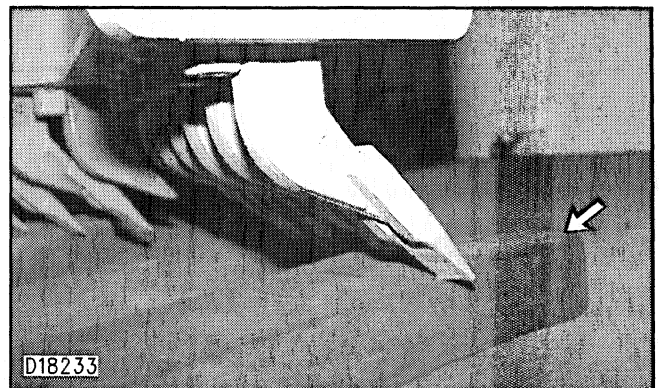

1. Block the scarifier. Do not block the scarifier any higher than necessary to remove the teeth.

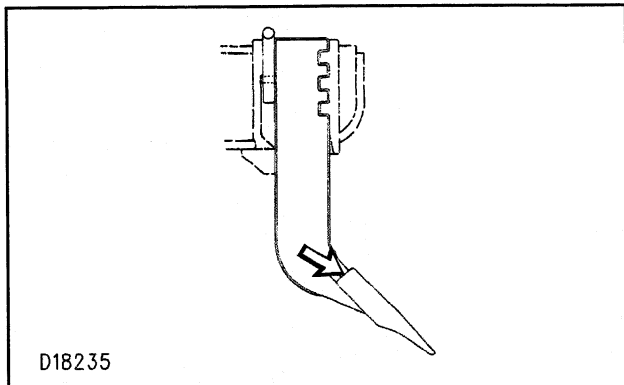

2. Remove the tooth from the tooth shank.
3. Clean the tooth shank.
4. Install the new tooth over the tooth shank.

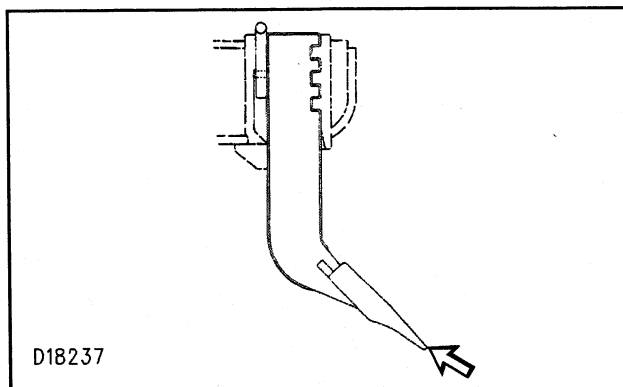

5. Drive the tooth onto the tooth shank.
6. Repeat for additional teeth replacement.
7. Raise the scarifier and remove blocking.

## Moldboard Wear Strip

### Adjust/Replace if Damaged

1. Rotate the blade 90 degrees to the machine. Lower the blade to the ground and stop the engine.

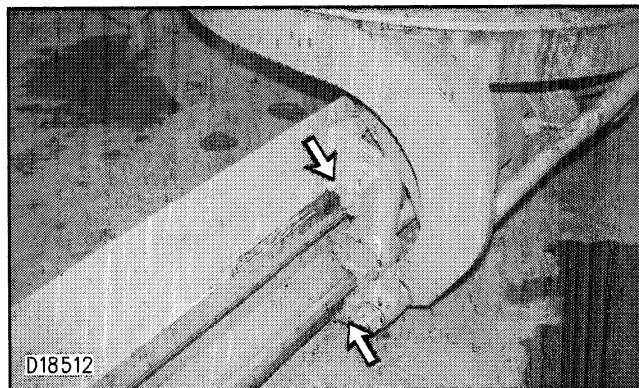

2. Remove the top and bottom retaining plates and visually inspect the wear strips. If the wear strips are worn close to the moldboard, replace the wear strips.
3. Install shims between the moldboard rail and the wear strips, at the minimum clearance location, to provide a clearance of 0.13 mm (.005 in) to 0.89 mm (.035 in).

Note: The required shims should be divided evenly between the upper and lower wear strips.

4. Install the top and bottom retaining plates.
5. Start the engine and sideshift the blade thru the entire range. Measure the clearance between the wear strips and the blade and determine where the minimum clearance occurs.
6. Stop the engine.



7. Repeat the procedure to adjust the tip bracket.

## Circle Drive Housing

### Check Oil Level

Check the oil level whenever a leak has developed or is suspected.

Wipe covers and surfaces around the opening before checking or adding oil.

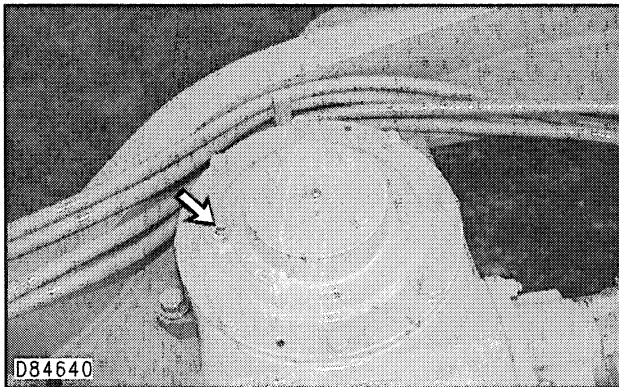

1. Remove the level/fill plug.
2. Maintain the oil level to the bottom of the opening. Add oil if necessary.
3. Install the level/fill plug.

## Drawbar Ball and Socket

### Check

With the blade 90 degrees to the frame and lowered to the ground, slowly move (inch) the machine to the rear, maintaining a light load between the drawbar ball and the adapter. Stop the machine and shut the engine off.

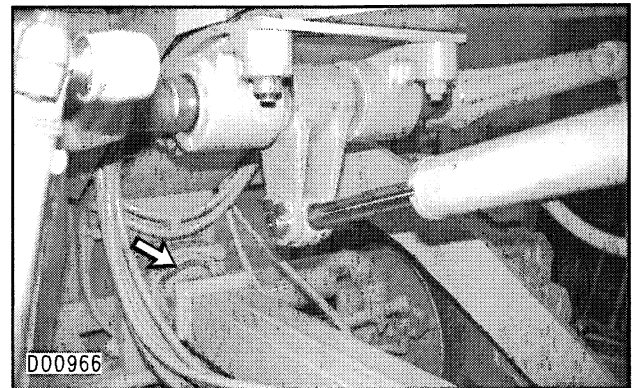

Measure the end play between the ball and the adapter with a feeler gauge. The end play should be  $0.6 \pm 0.2$  mm (.02  $\pm$  .01 in). Adjust if necessary.

### Adjust

1. Support the drawbar and the circle.
2. Remove the bolts and move the drawbar back or the machine forward.

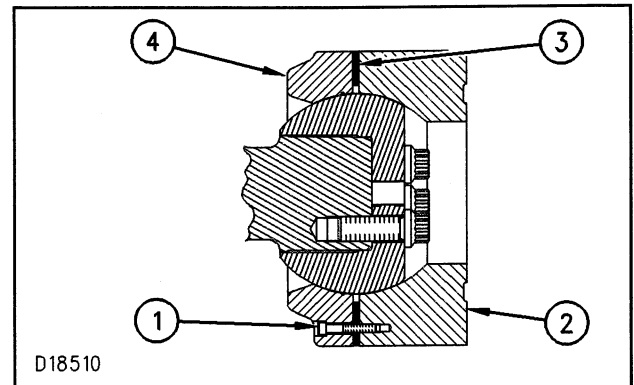

124  
Maintenance Section  
When Required

3. Remove the two cap screws (1) from the adapter (2) and remove the adapter.
4. Remove or install the shims (3) as required, to obtain  $0.6 \pm 0.2$  mm ( $.02 \pm .01$  in) end play.
5. Install the two cap screws (1) in the adapter. Rotate the socket (4) by hand. The socket should rotate freely on the ball.

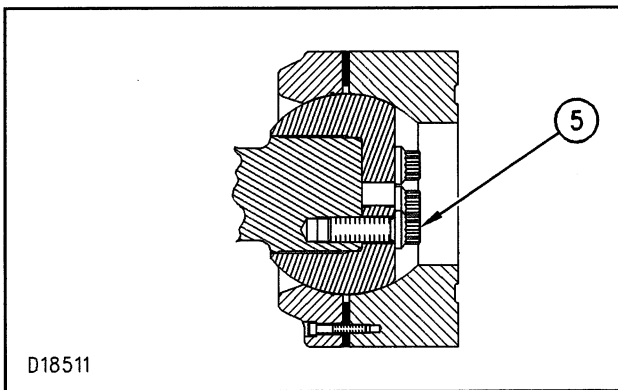

6. Check the torque on the bolts (5) that hold the ball and socket in place. The correct torque is  $500 \pm 20$  N•m ( $370 \pm 15$  lb ft).
7. Assemble the drawbar to the bolster. Tighten the bolts to a torque of  $700 \pm 27$  N•m ( $515 \pm 20$  lb ft).

## Blade Circle

### Check/Adjust

#### Circle and Drawbar

1. Rotate the blade 90 degrees to the frame.

Note: Install the C-clamps before grounding the blade.

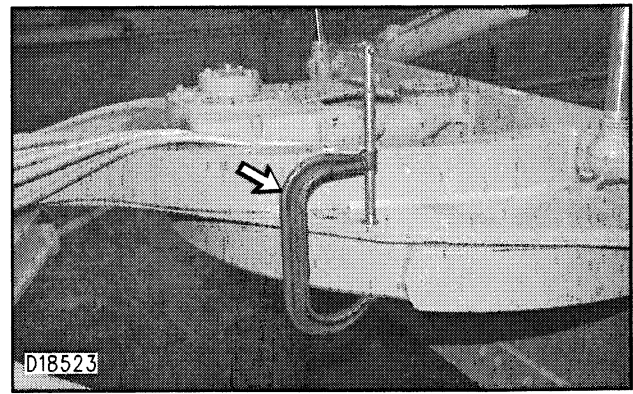

2. Install two C-clamps to the front of the circle and the drawbar. Tighten each clamp until the wear strips are in contact with the top of the circle and the bottom of the drawbar.
3. Lower the blade to the ground. Stop the engine.

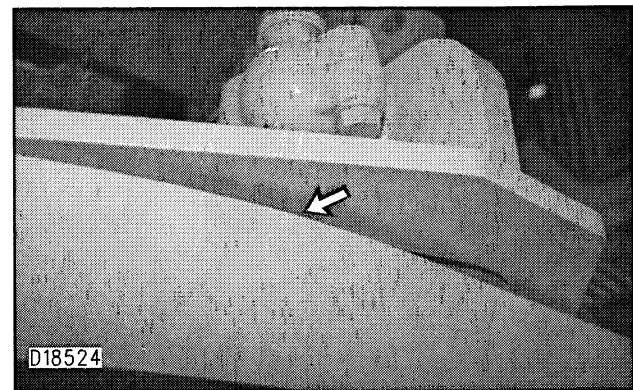

4. Measure the distance between the top surface of the circle and the drawbar. If the distance is less than 1.5 mm (.06 in) replace the wear strip.
5. Inspect the wearstrip and drawbar. The wearstrip should be in running contact with the circle. If they are not in contact, shims can be used. Refer to Special Instruction, SMHS7185 for installation procedures.

Note: No more than two shims are to be installed under any one wearstrip.

### Circle to Shoe Clearance

Rotate the blade 90 degrees to the frame.

Note: Install the C-clamp before lowering the blade to the ground.

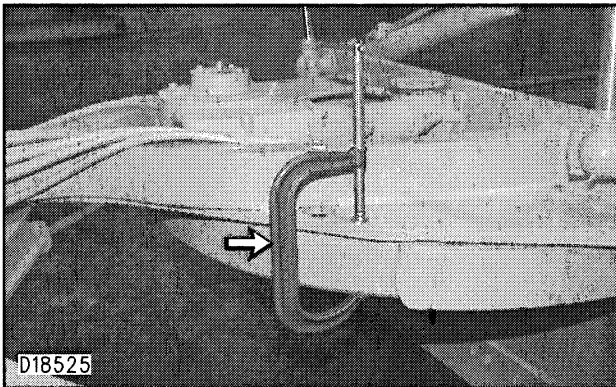

**1.** Install C-clamps to the front of the circle and the drawbar. Tighten each clamp until the wear strips are in contact with the top of the circle and the bottom of the drawbar.

**2.** Lower the blade to the ground. Stop the engine.

Note: The wear strips should be in contact with the circle and drawbar, 360 degrees around the circle.

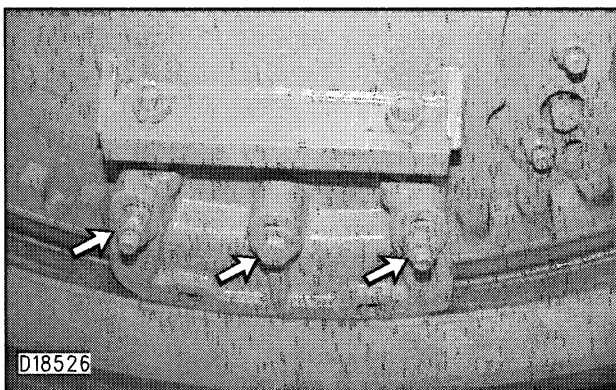

**3.** Make sure the shoe mounting bolts are tight and the wear strips are completely seated in the shoes.

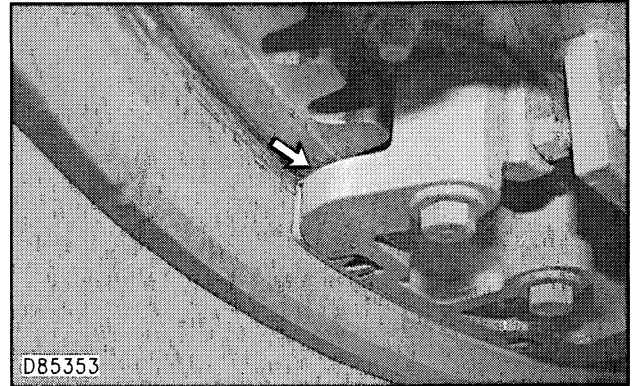

**4.** Measure the clearance between the bottom of the circle and the top of the shoes wearstrip. Maintain a clearance of approximately 0.5 mm (.02 in). Add or remove shims between the shoes, as required, to maintain the proper clearance.

Note: The proper clearance will permit free rotation of the circle through 360 degrees of rotation.

Adjust one shoe at a time.

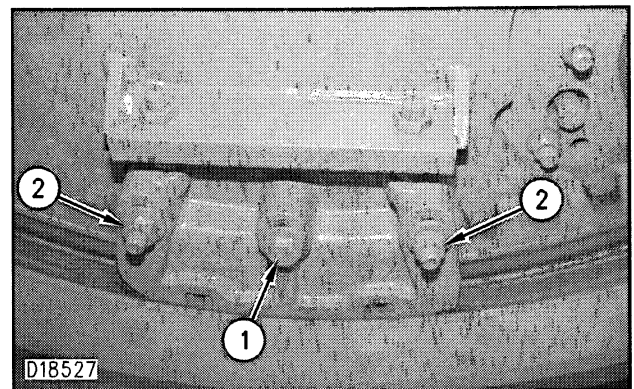

**5.** Loosen the screws (1) and remove the mounting bolts (2).

**6.** Add or remove shims as required.

**7.** Install the mounting bolts (2) and tighten the screws (1).

**8.** Check the clearance after each shoe has been adjusted for proper clearance. Make adjustments if necessary.

Note: The circle must rotate freely without binding after all adjustments have been made.



### Circle Pinion and Circle Shoe

Note: The pinion and circle tooth engagement is determined by the circle shoe adjustment. To reduce wear to the pinion and circle teeth and to improve accuracy of adjustment, clean the circle and pinion of dirt and abrasive material. Apply clean lubricant to the pinion and circle teeth after the adjustment has been made.

**1.** Rotate the blade 90 degrees to the frame and lower the blade to the ground. Slowly move (inch) the machine forward and apply the parking brake. This will hold a light load between the front shoe wear strips and the circle. Stop the engine.

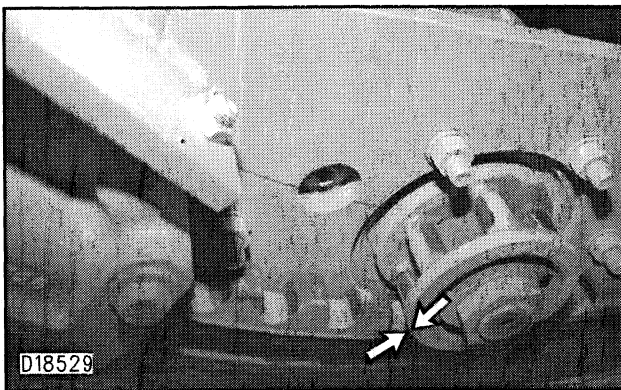

**2.** Measure the clearance between the bottom flange of the pinion and the inner machined surface of the circle. If the clearance is less than  $50.0 +2.5 - .5$  mm ( $1.97 +.10 - .02$  in) adjust the clearance.

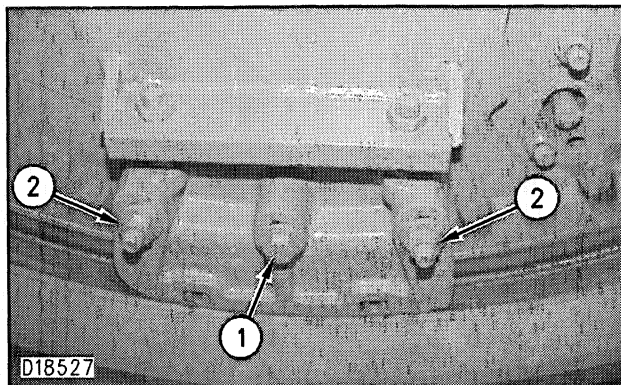

**3.** Loosen the front shoe mounting bolts (1) and adjusting the screws (2).

**4.** Loosen the rear shoe mounting bolts and back off the adjusting screws.

**5.** Turn the front shoe adjusting screws (2) in or out to obtain a minimum clearance of  $50.0 +2.5 - .5$  mm ( $1.97 +.10 - .02$  in).

**6.** Repeat the procedure for the other front shoe.

Note: The front shoes must be adjusted the same.

If the correct adjustment measurement cannot be obtained due to worn front shoe wear strips, replace the worn wear strips and repeat the procedure.

**7.** Tighten the shoe mounting bolts and the adjustment screw locknuts.

Note: The adjusting screws must be tight against the shoes before the mounting bolts are tightened.

**8.** With the pinion clearance set and the front shoes contacting the circle, measure the distance between each rear shoe wearstrip and the circle. The clearance is to be between 0.76 mm and 2.00 mm (.030 and .079 in).

**9.** Adjust the rear shoes in the same manner as the front shoes.

If the correct adjustment measurement cannot be obtained due to worn rear shoe wear strips, replace the worn wear strips and repeat the procedure.

Note: When measuring between the wear strips and the circle, make sure the wear strips are completely seated in the shoes.

**10.** Tighten the front and rear shoe mounting bolts and adjusting screw locknuts.

## Blade Lift Cylinder Sockets

### Adjust/Replace

Rotate the blade 90 degrees to the frame and lower the blade to the ground.

1. Operate the blade lift cylinders, observe the socket joints. If the joint moves without blade movement, adjustment is necessary.

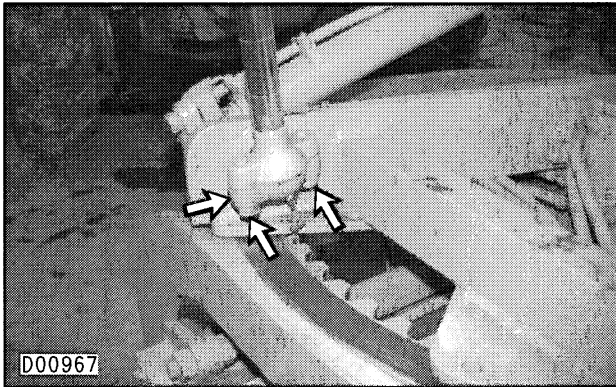

2. Remove the bolts from the socket cap and remove the cap.

3. Remove one shim from either side of the joint to reduce clearance.

Note: If removal of two shims are required, remove one from each side of the joint.

4. Install and tighten bolts.

5. Check for movement. If movement is observed repeat the procedure.

Note: If no shims remain to be removed, install new inserts. Install one insert on each side of the joint. Install new shims as required.

## Centershift Cylinder Sockets

### Adjust/Replace

Rotate the blade 90 degrees to the frame and lower the blade to the ground.

1. Operate the centershift cylinder, observe the socket joints. If the joint moves without drawbar movement, adjustment is necessary.

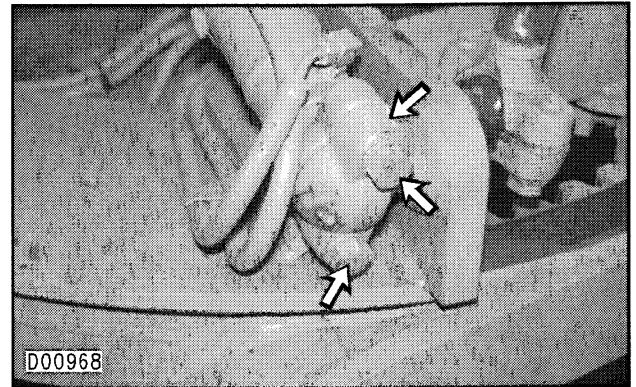

2. Remove the bolts from the socket cap and remove the cap.

3. Remove one shim from either side of the joint to reduce clearance.

Note: If removal of two shims are required, remove one from each side of the joint.

4. Install and tighten bolts.

5. Check for movement. If movement is observed repeat the procedure.

Note: If no shims remain to be removed, install new inserts. Install one insert on each side of the joint. Install new shims between the insert and the rod or cap, as required.



**Blade Accumulator (If Equipped)  
Change**



**Steering Accumulator  
Check Precharge**

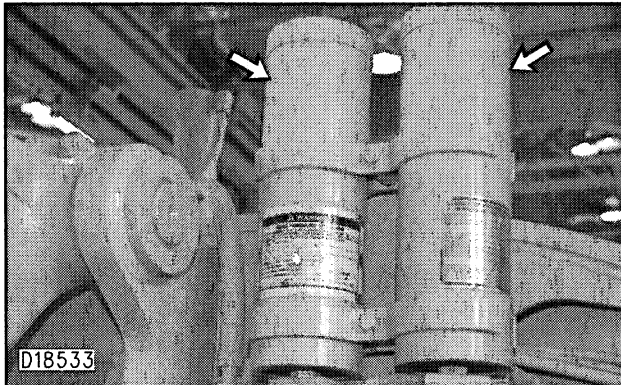

If lift cylinder movement becomes loose, check the nitrogen precharge. Add nitrogen if necessary. Consult your Caterpillar dealer for correct checking and filling procedures and recommended pressure.

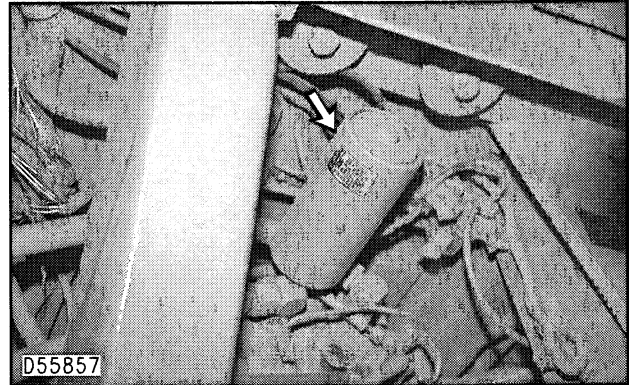

**Bottom view of operator's platform.**

If steering movement is affected when turning and using other hydraulic equipment, check the nitrogen precharge. Add nitrogen if necessary. Consult your Caterpillar dealer for correct checking and filling procedures and recommended pressure.

## Filter Inspection

### Inspect Used Oil Filter for Debris

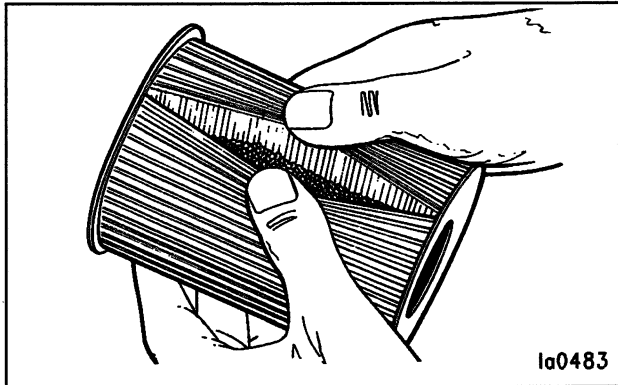

Element with debris

Use a 4C-5084 Filter Cutter (formerly 6V-7905) to cut the filter element open. Spread pleats apart and inspect the element for metal and other debris. An excessive amount of debris in the filter element can indicate a possible failure.

Use a magnet to differentiate between ferrous and nonferrous metals found in the filter element.

Ferrous metals can indicate wear on the steel and cast iron parts.

Nonferrous metals can indicate wear on the aluminum parts of the engine, such as main, rod and/or turbocharger bearings.

Due to normal wear and friction, it is not uncommon to find small amounts of debris in the filter element. Consult your Caterpillar dealer to arrange for further analysis if an excessive amount of debris is found.

Use of an oil filter element not recommended by Caterpillar can result in severe engine damage to engine bearings, crankshaft and other parts. This can permit larger particles in unfiltered oil to enter the lubricating system and cause damage.

## Every 10 Service Hours or Daily

*You must read and understand the warnings and instructions contained in the Safety Section of this manual, before performing any operation or maintenance procedures.*

### Engine Crankcase Oil

#### Check the Oil Level

---

**NOTICE**

Do not overfill the crankcase. Engine damage can result.

---



**1.** Open the left side engine access door located behind the operator's compartment.

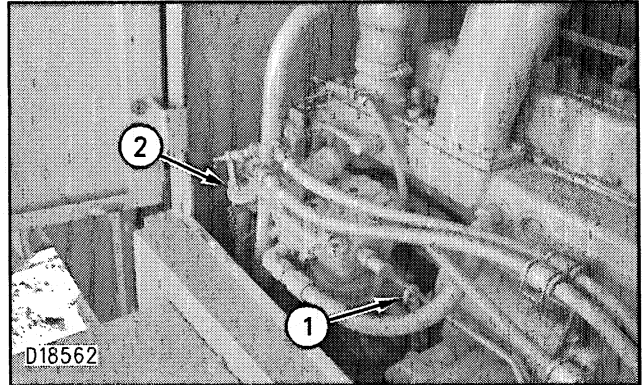

**2.** Maintain the oil level between the marks on the dipstick (1) with the engine running.

Maintain the oil level on the engine stopped side of the dipstick (1) between the marks, with the engine stopped.

- 3.** Remove the oil fill cap (2) and add oil if necessary.
- 4.** Clean and install the fill cap.
- 5.** Close the access door.

## Radiator

### Look at the Coolant Level

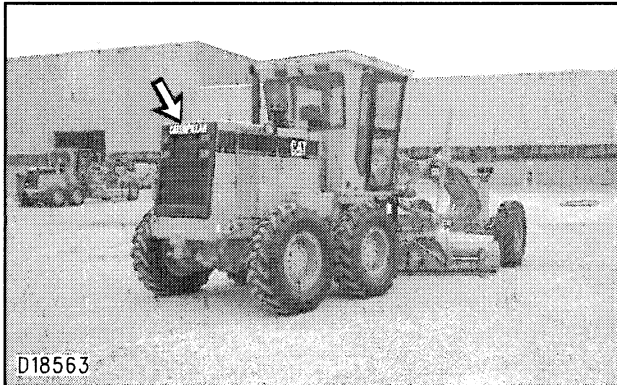

The radiator cap is located in the top hood of the machine at the left rear.



1. Open the cover and remove the radiator cap slowly to relieve pressure.
2. Maintain the coolant level to within 13 mm (.5 in) of the bottom of the fill pipe. If it is necessary to add coolant daily, check for leaks.
3. Inspect the cap and cap seal for damage, deposits or foreign material. Clean the cap with a clean cloth or replace the cap if it is damaged.
4. Install the cap.
5. Inspect the radiator core for debris and plugging. Clean if necessary.

Compressed air is preferred, but high pressure water or steam can be used to remove dust, leaves and general debris from a radiator. Clean as required the by condition of the radiator.

## Hydraulic Tank Oil

### Check the Oil Level



The hydraulic oil sight gauge is located on the left side of the machine.

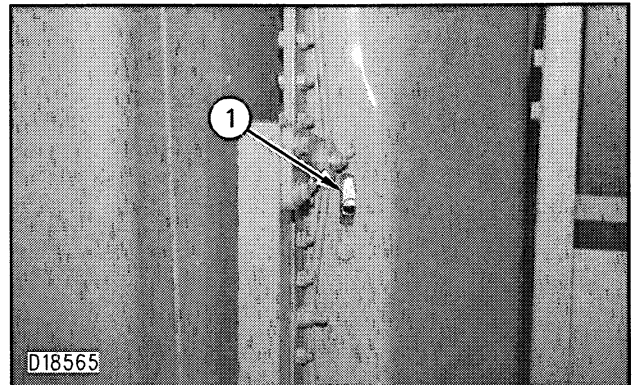

1. Maintain the oil level above the ADD COLD mark on the sight gauge (1).

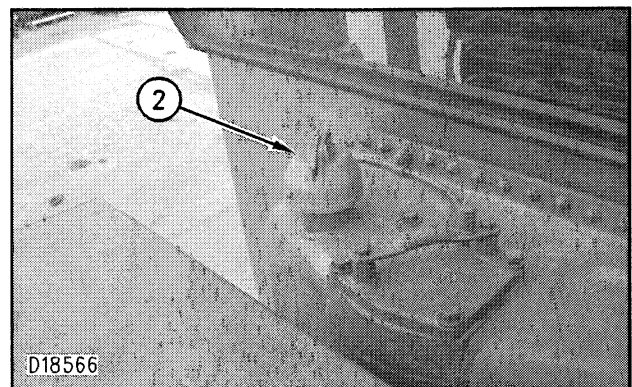

2. Remove the oil fill cap (2) and add oil, if necessary, through the fill tube.
3. Clean and install the fill cap.

## Circle Pinion Teeth

Lubricate

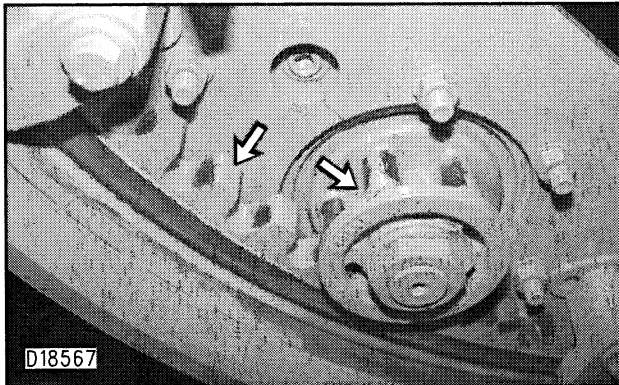

1. Clean the dirt and old grease from the circle and pinion teeth.
2. Apply grease to the circle and pinion teeth.

## Circle Top

Lubricate

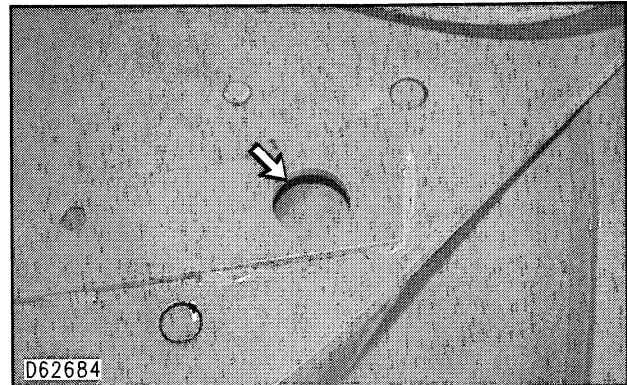

Apply dry lubricant to the circle top.



## Walk-Around Inspection

### Inspect Machine

#### NOTICE

Accumulated grease and oil on a machine is a fire hazard. Remove this debris with steam cleaning or high pressure water, at least every 1000 hours or each time any significant quantity of oil is spilled on a machine.

Note: Keep a close watch for leaks. If leaking is observed, find the source and correct the leak. Check the fluid levels more frequently than the recommended periods if leaking is suspected or observed.

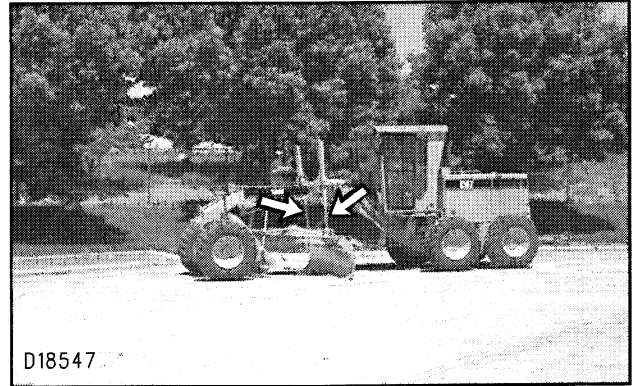

Inspect the blade linkage for damage, loose or missing bolts. Repair of necessary.



Inspect the engine precleaner for dirt buildup. Remove dirt from the screen. Make sure the air filter indicator piston is not in the red zone.

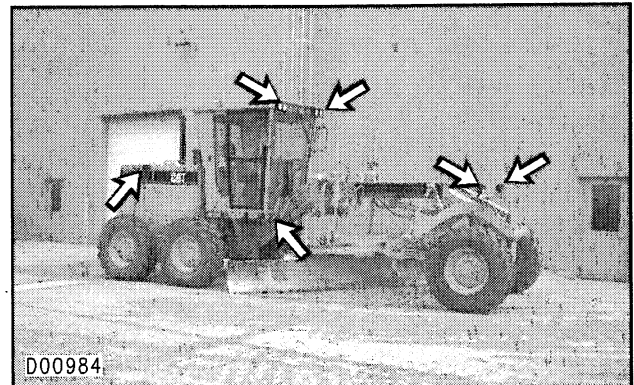

Inspect the lights for broken bulbs and lenses. Replace if broken.



Inspect the blade and end bits for damage or excessive wear. Repair if damaged.



Inspect and remove any trash buildup in the engine compartment.

**134**  
**Maintenance Section**  
**Every 10 Service Hours or Daily**



Inspect and remove dirt and trash buildup in the articulation area.



Inspect all engine attachment belts for worn cracked or frayed edges. Replace if worn, cracked, frayed or broken.



Inspect and remove dirt and trash buildup on the tandem housings. Check and repair leaks.



Inspect the hydraulic system for leaks. Inspect the tank, cylinder rod seals, hoses, tubes, plugs, joints and fittings. Correct any leaks.



Inspect the cooling system for leaks, faulty hoses and trash buildup. Correct any leaks and remove any trash from the radiator.



Inspect the front wheel spindle bearing housings for leaks. If a leak is found contact your Caterpillar dealer for inspection and, if necessary, repairs.



D18553

Inspect the circle drive for leaks and repair leaks.



D18560

Inspect transmission for leaks.

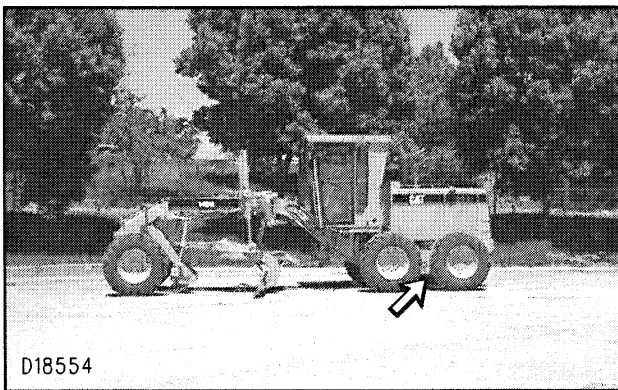

D18554

Inspect under the machine for leaks in the differential and tandems.



D18556

Be sure the covers and guards are firmly in place. Inspect for damage.

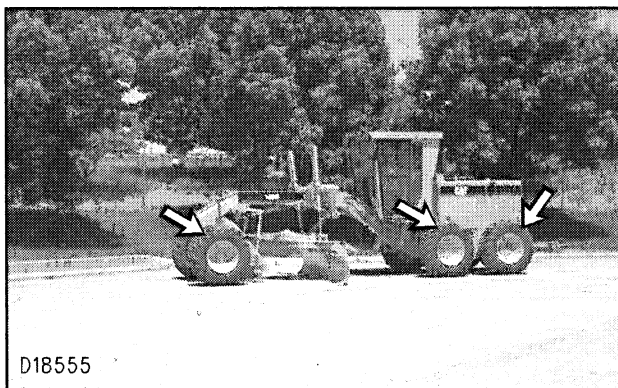

D18555

Inspect tires (front and rear) for damage and proper inflation. Replace any missing valve caps.



D17982

Inspect the steps, walkways and handholds for their condition and cleanliness. Inspect the Rollover Protective Structure (ROPS) (if equipped) for damage. If repair is necessary contact your Caterpillar dealer. Tighten any loose ROPS bolts.





Inspect the operator's compartment for cleanliness. Keep it clean.

Adjust the rearview mirrors (if equipped) for best vision.

### Window Cleaning

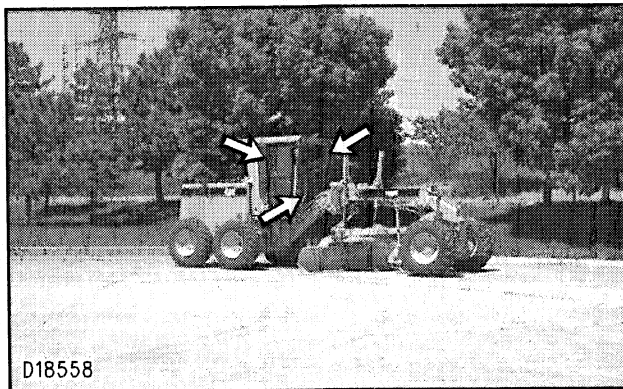

Use commercially available window cleaning solutions to clean the windows. Clean the outside windows from the ground, unless handholds are available.

### Air Reservoir

#### Drain Moisture and Sediment

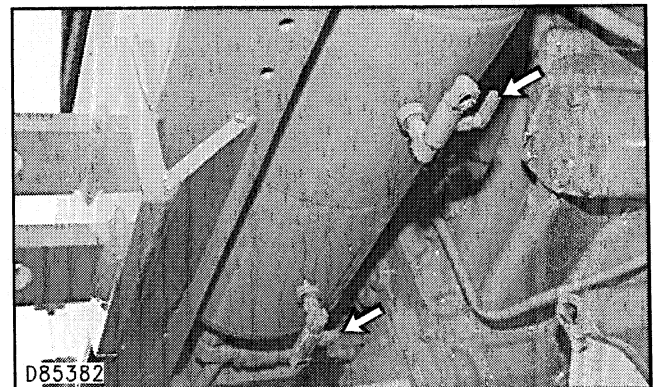
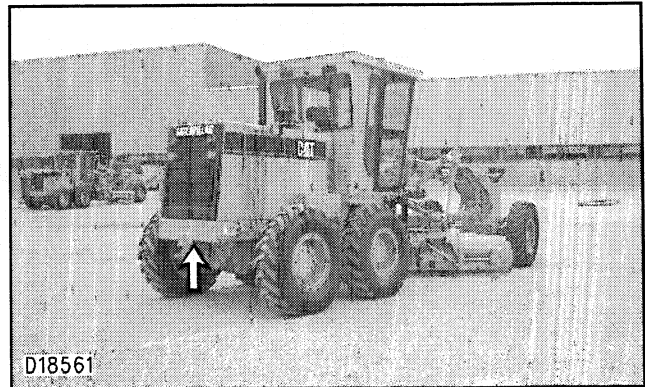

Open the drain valves, one on each end of the reservoir. Allow all condensation to drain into a container. Close the drain valves.

## Fuel Tank

### Drain the Water and Sediment



The drain valve is located at the left side of the machine under the fuel tank.

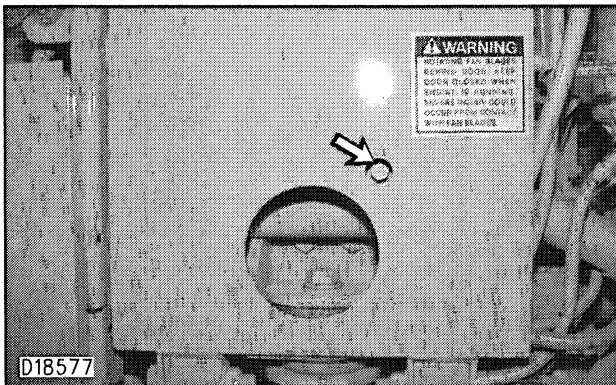

1. Open the drain valve and allow the water and sediment to drain into a suitable container.
2. Close the drain valve.

## Seat Belt

### Inspect for Wear or Damage

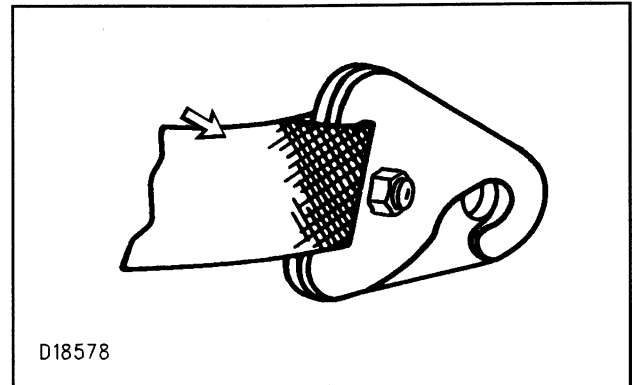

Replace the seat belt after three years of usage, regardless of appearance.

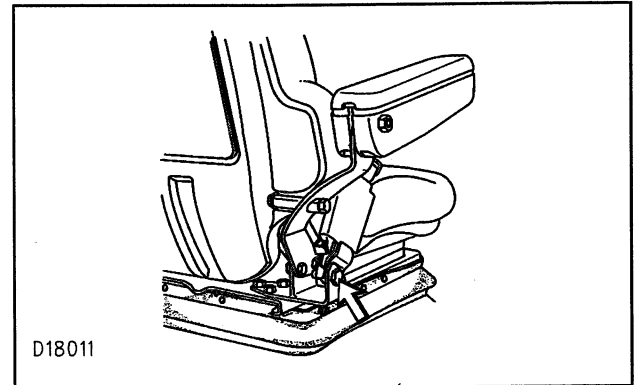

Seat belt and mounting hardware must be inspected for wear or damage before operating the machine. Replace the belt or mounting hardware if worn or damaged.

## Brakes, Indicators and Gauges

### Test for Proper Function

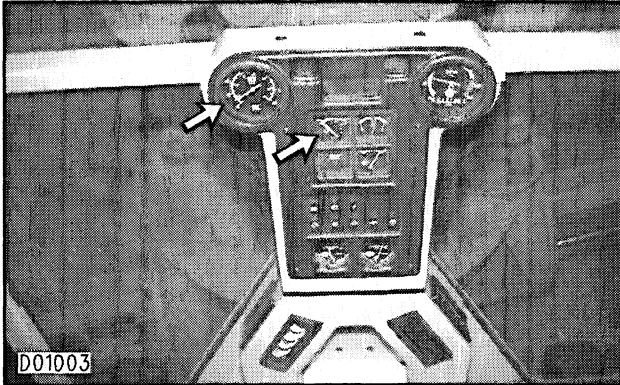

Look for broken gauge lenses or indicator lights, switches, etc.

Start the engine.

Look for inoperative gauges.

Turn all machine lights on. Check for proper operation.

Sound the forward horn.

Move the machine forward and test the service brakes. If the service brakes do not function properly refer to the topic Brakes in the Every 250 Service Hours or Monthly Section of this manual.

Stop the engine.

Make any needed repairs before operating.

## Backup Alarm

### Test

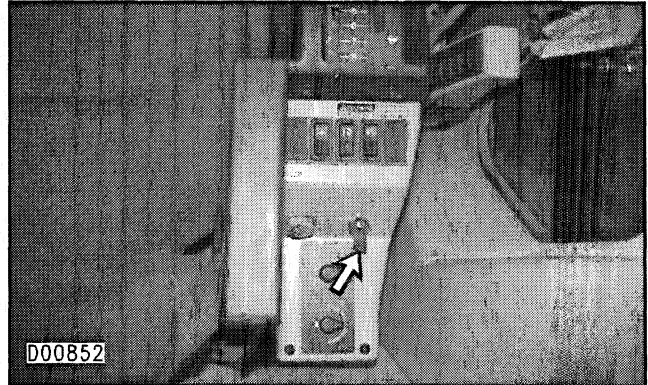

Turn the start switch to ON to perform the test.

Apply the service brake. Move the transmission control lever into Reverse.

The alarm should start to sound immediately. It will continue to sound until the transmission control lever is moved to center Neutral or Forward.

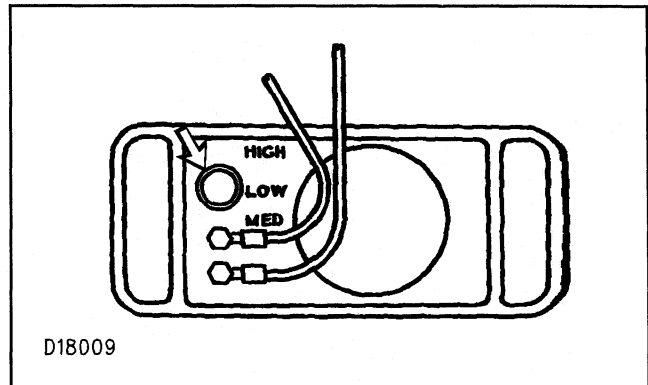

The sound level can be adjusted by moving the adjustment on the back of the alarm to meet operating requirements. The alarm is set at the highest sound level when shipped from the factory. The setting should remain on high, unless the job site requires a lower level.

The backup alarm is located on the rear of the machine.

## Every 50 Service Hours or Weekly

*You must read and understand the warnings and instructions contained in the Safety Section of this manual, before performing any operation or maintenance procedures.*

### Cab Air System (If Equipped)

#### Clean Filters

Note: Clean the filters more often in dusty conditions.

#### Outside Filters

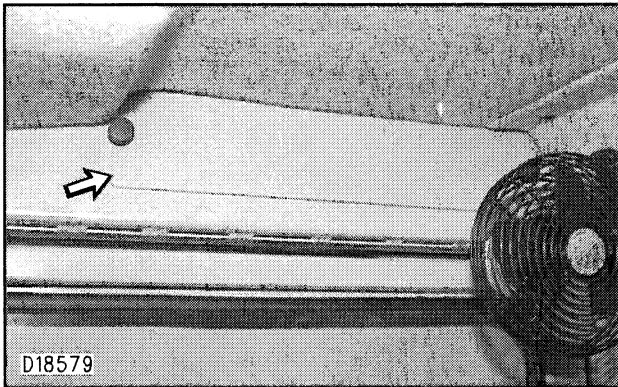

The cab air system has two outside filters, one above each cab door.

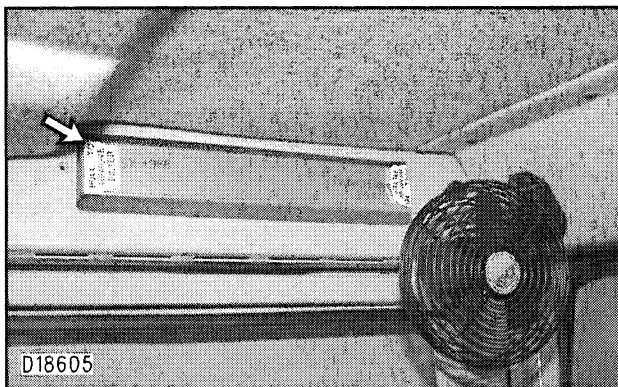

1. Remove the filter cover.
2. Remove the filter elements. Clean the filter elements with pressure air or wash the elements in warm water and a nonsudsing household detergent.

3. Rinse in clean water and air dry thoroughly.
4. Install the filter elements. Install the filter cover.

#### Inside Filter

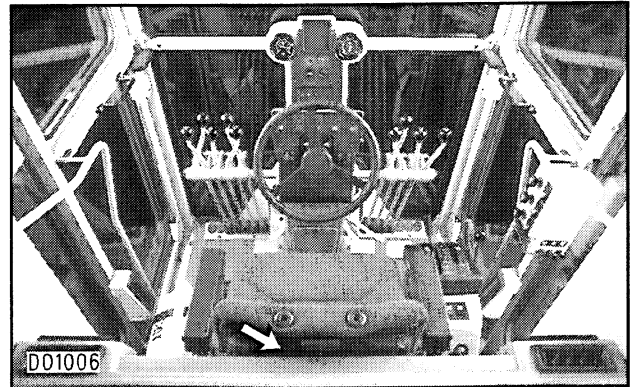

The inside cab air system filter is located behind the operator's seat.

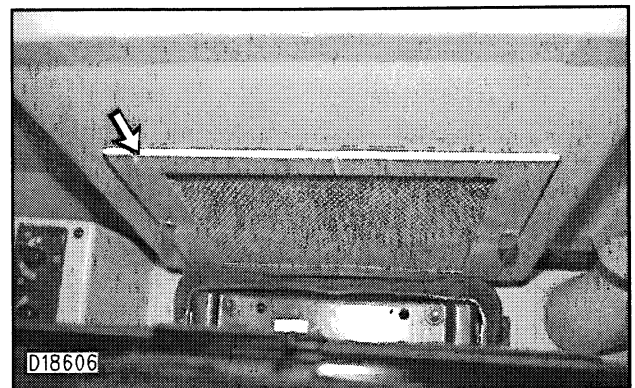

1. Remove the filter cover.
2. Remove the filter element. Clean the filter element with pressure air or wash the element in warm water and a nonsudsing household detergent.
3. Rinse in clean water and air dry thoroughly.
4. Install the filter element. Install the filter cover.

### Changing Filters

Note: Change the filters when required.

#### Outside Filters

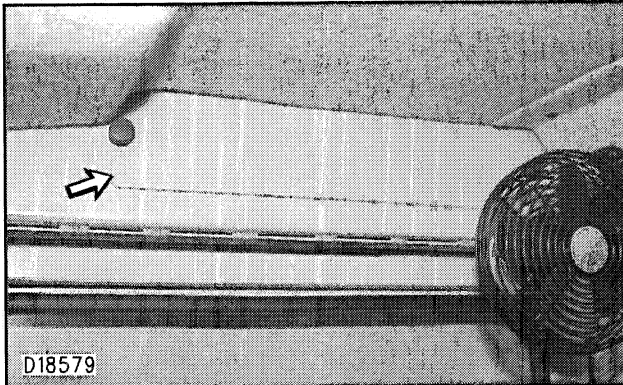

1. Remove the filter cover.
2. Remove the filter elements and discard.
3. Install the new filter elements.

#### Inside Filter

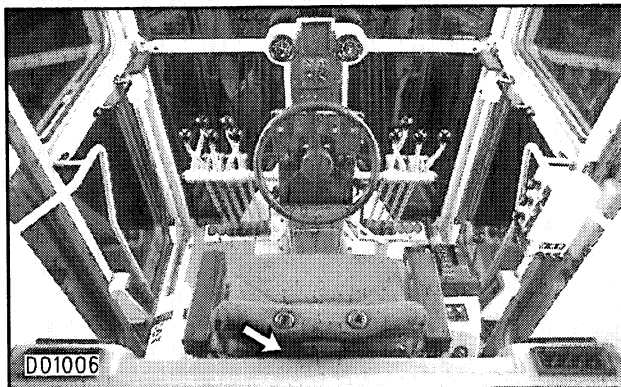

1. Remove the filter cover.
2. Remove the filter element and discard.
3. Install the new filter element.

### Axle Oscillating Bearing

#### Lubricate Fittings

Wipe all fittings before lubricating.

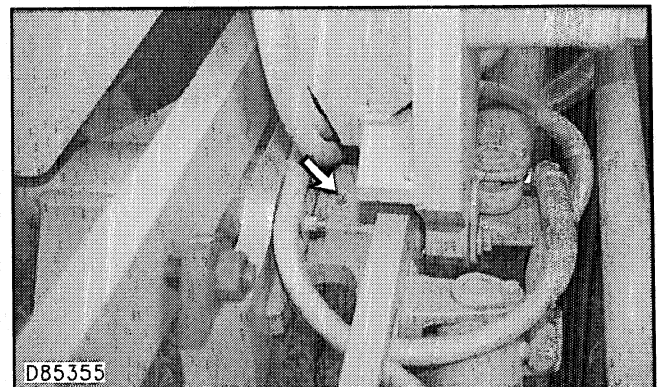

Lubricate one axle fitting.



## Leaning Wheel Bearings

### Lubricate Fittings

Wipe all fittings before lubricating.



D18611

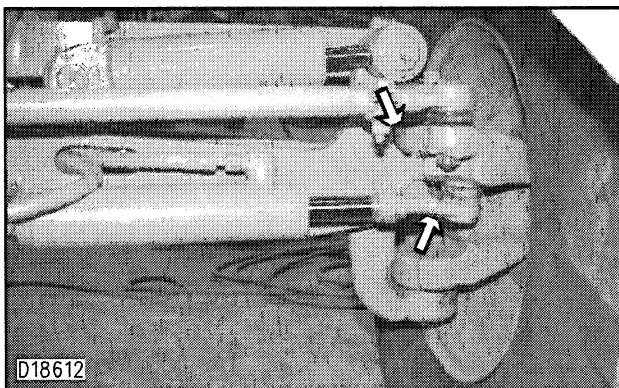

D18612

Lubricate two fittings on each of the front wheels.

There is a total of four fittings.

## Leaning Bar Bearings

### Lubricate Fittings

Wipe all fittings before lubricating.

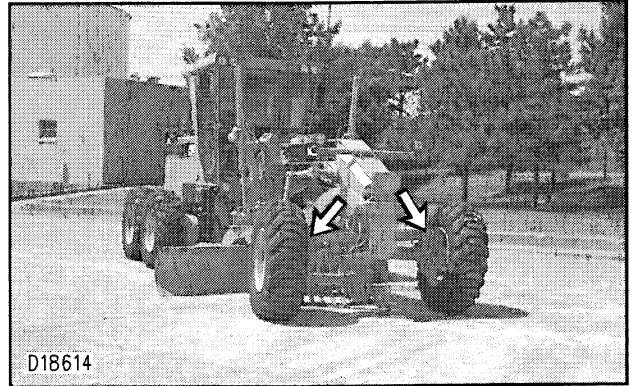

D18614

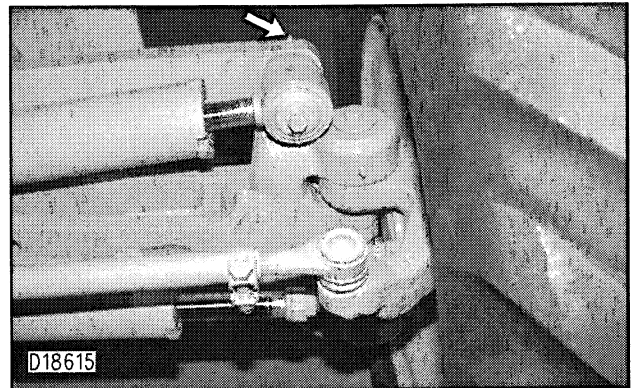

D18615

Lubricate one fitting on each of the front wheels.

There is a total of two fittings.

### Leaning Wheel Cylinder Bearings Lubricate Fittings

Wipe all fittings before lubricating.

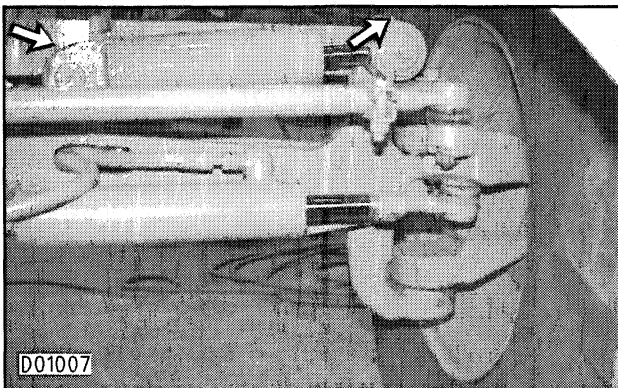

Lubricate one fitting on each end of the leaning wheel cylinder.

There is a total of two fittings.

### King Pin Bearings Lubricate Fittings

Wipe all fittings before lubricating.

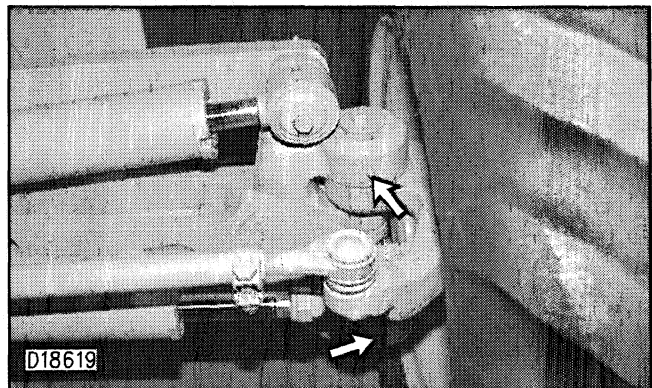

Lubricate two fittings on each of the front wheels king pins.

There is a total of four fittings.

## Articulation Bearings

### Lubricate Fittings

Wipe all fittings before lubricating.



## Drawbar Draft Ball

### Lubricate Fitting

Wipe all fittings before lubricating.

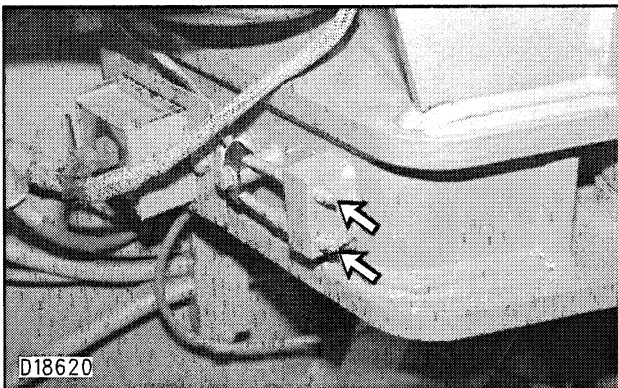
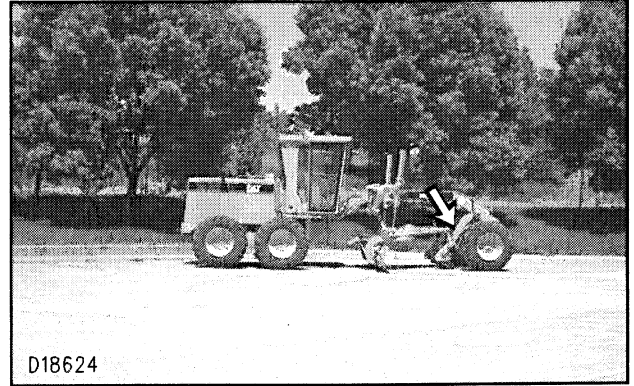

Lubricate one fitting on the upper articulation bearing.

Lubricate one fitting on the lower articulation bearing.

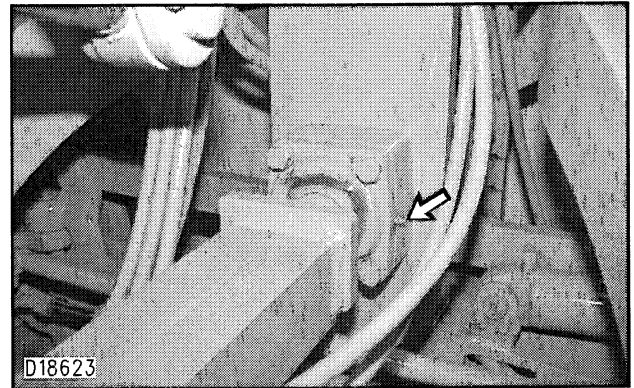

Lubricate one fitting on the drawbar draft ball.



### Ripper (If Equipped)

#### Lubricate Fittings

Wipe all fittings before lubricating.

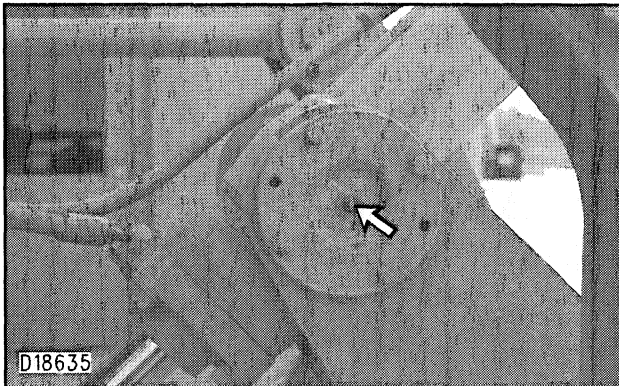
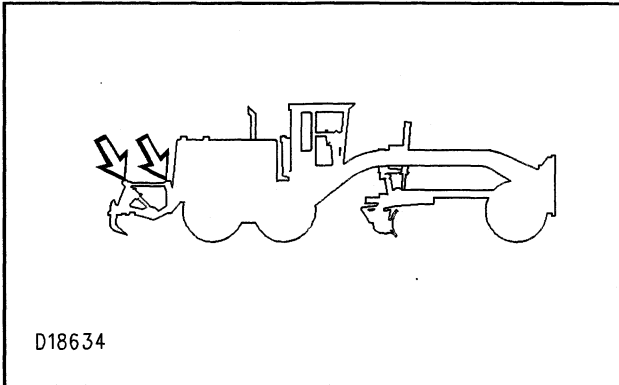

Lubricate one fitting on each side of the trunnion.  
There is a total of two fittings.

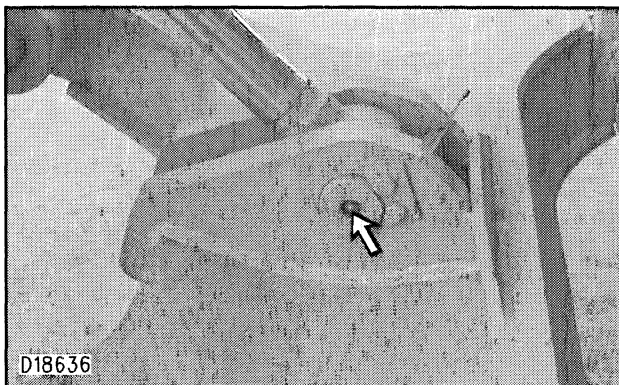

Lubricate one fitting on the rod end of the cylinder.  
There is a total of three fittings.

### Scarifier (If Equipped)

#### Lubricate Fittings

Wipe all fittings before lubricating.



Lubricate two fittings on each side of the machine.  
There is a total of four fittings.

## Tires

### Check Inflation Pressure

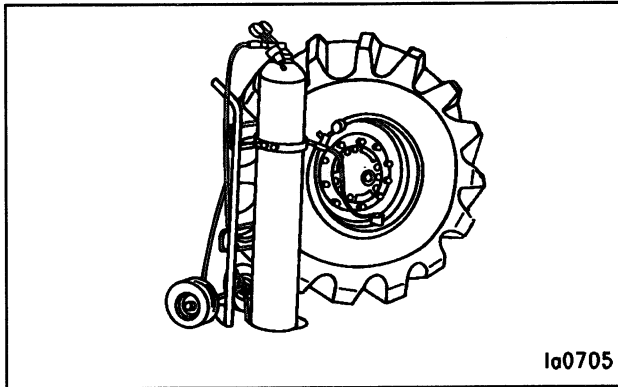

Measure the tire pressure on each tire. Consult your Caterpillar dealer for correct load rating and operating pressures.

Inflate the tires, if necessary. See the Tire Inflation Information Section of this manual.

## Every 250 Service Hours or Monthly

*You must read and understand the warnings and instructions contained in the Safety Section of this manual, before performing any operation or maintenance procedures.*

### Engine Oil and Filter

#### Change the Oil and Filter

Note: Articulate the machine to the left to allow for better access to the engine oil drain plug.

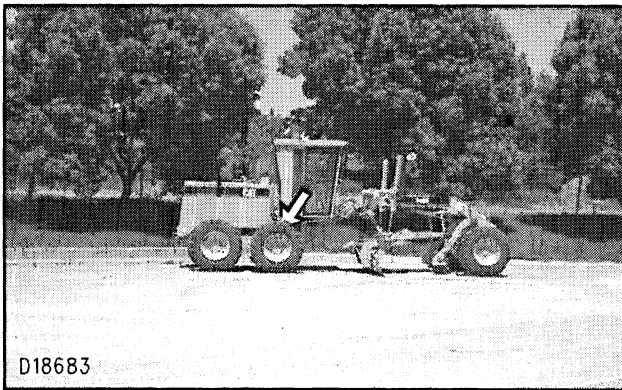

1. Open the crankcase drain valve. Allow the oil to drain into a suitable container. Close the drain valve.
2. Open the left access door of the machine.

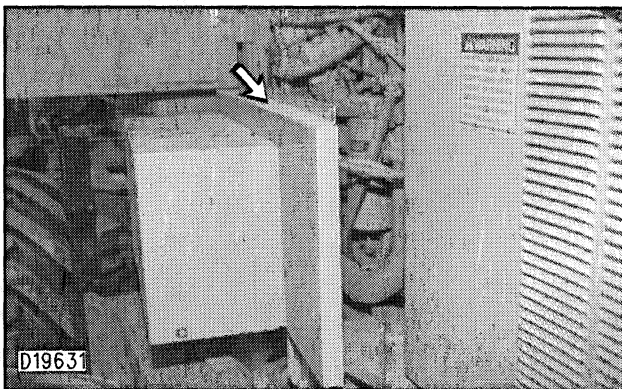

Note: The left side cover panel may be loosened and moved outward or removed to improve access to the filter element. Remove the cover panel rear mounting bolts, loosen the front mounting bolt and move the rear of the cover panel outward. Replace the side cover panel when the new filter element has been installed.

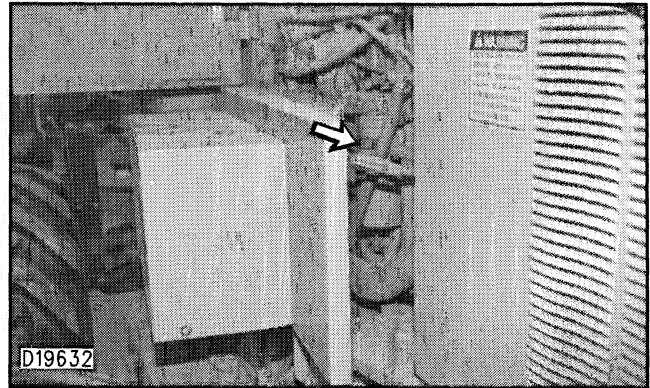

3. Remove the filter element with a strap type wrench. Refer to Filter Inspection in the When Required Section.
4. Clean the filter housing base. Make sure all of the old filter gasket is removed.
5. Apply a light coat of engine oil to the gasket of the new filter.
6. Install the new filter by hand. When the gasket contacts the filter base, tighten the filter an additional three-quarters of a turn.

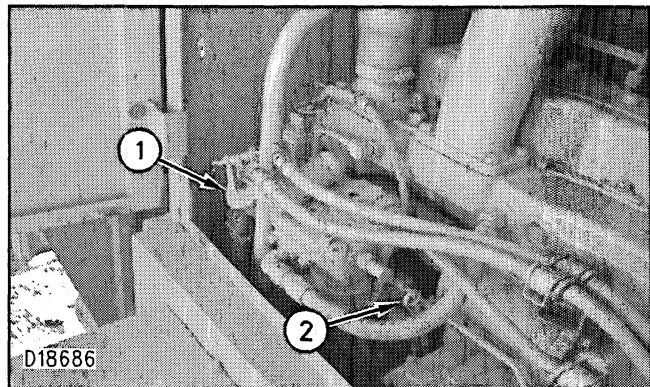

7. Remove the oil fill plug (1). Fill the crankcase with new oil. See the Lubricant Viscosities and Refill Capacities. Clean and install the fill plug.
8. Start the engine and allow the oil to warm. Check for leaks.
9. With the engine running, maintain the oil on the dipstick (2) between the marks on the low idle side of the dipstick. Add oil if necessary.
10. Install the access cover and stop the engine.

## Cooling System (For Machines That Are Not Equipped with Caterpillar's Long Life Coolant/Antifreeze)

### Add Supplemental Coolant Additive/Replace Element

Refer to the Cooling System Specifications Section of this manual for all cooling system requirements.

Use the 8T-5296 Test Kit to check for concentration.

---

#### NOTICE

Excessive additive (greater than the recommended 6% initial fill) together with concentrations of antifreeze greater than 60% cause deposits to form and can result in radiator tube blockage and overheating.

---

### Liquid Supplemental Coolant Additive

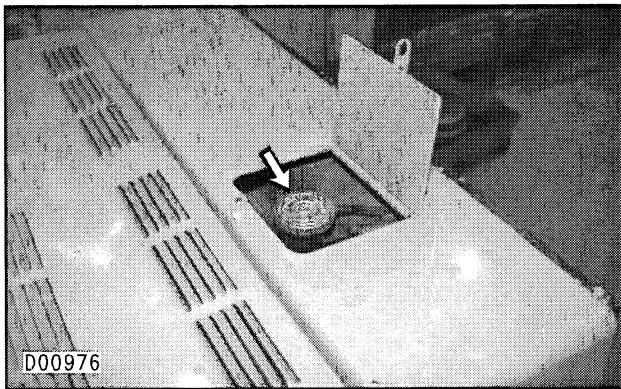

1. Loosen the fill cap slowly to relieve pressure. Remove the cap.
2. It may be necessary to drain enough coolant from the radiator to allow for the addition of the liquid cooling system additive.
3. Add 0.24 liters (.500 pint) of additive for every 38 liters (10 U.S. gallons) of cooling system capacity.
4. Install the fill cap.

## Centershift Cylinder

### Lubricate Fittings

Wipe all fittings before lubricating.

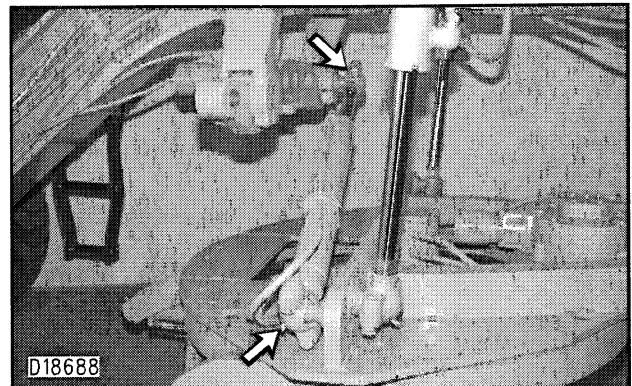
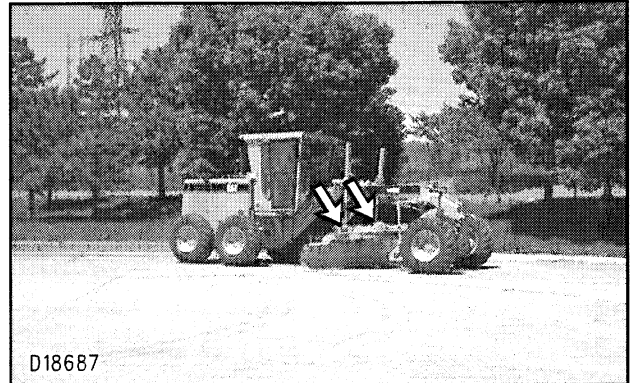

Lubricate one fitting on each end of the centershift cylinder.

There is a total of two fittings.

## Blade Lift Cylinders Lubricate Fittings

Wipe all fittings before lubricating.

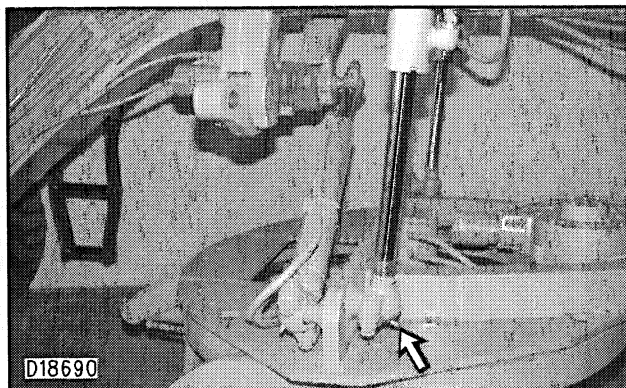

Lubricate one fitting on each blade lift cylinder.

There is a total of two fittings.

## Transmission and Differential Housing

### Check the Oil Level



**1.** Open the access door located on the right side of the machine.

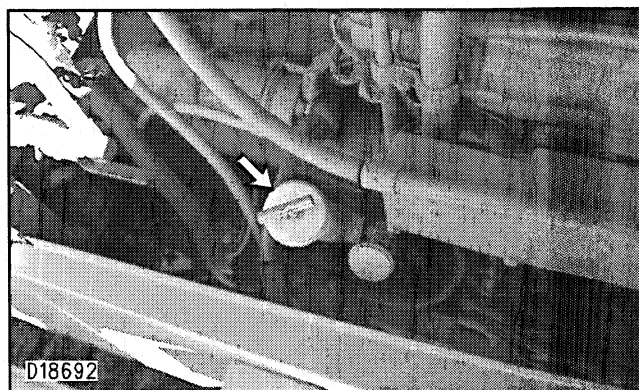

**2.** Maintain the oil between the marks on the dipstick at Low Idle.

**3.** Add oil if necessary.

**4.** Clean and install the fill cap.

**5.** Close the access door.



## Tandem Drive Housings

### Check

Clean the surface area around level/fill plug before checking the oil level.

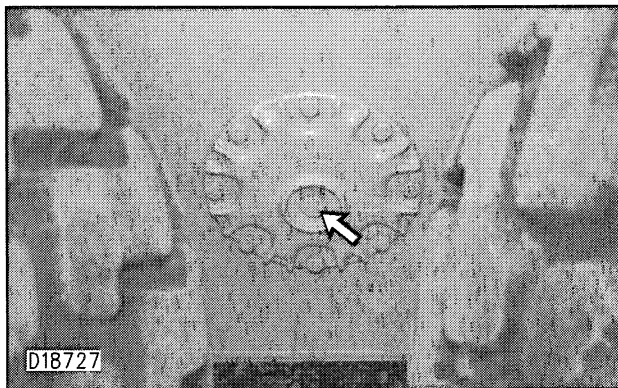

1. Remove the level/fill plug.
2. Maintain the oil level to the bottom of the level/fill plug opening. Add oil if necessary.
3. Install the level/fill plug.

## Brakes

### Test Service Brake Holding Ability

#### **! WARNING**

**Personal injury can result if the machine moves while testing.**

**If the machine begins to move during test, reduce the engine speed immediately and engage the parking brake.**

Be sure the area around machine is clear of personnel and obstructions.

Test the brakes on a dry, level surface.

Fasten the seat belt before testing the brakes.

The following tests are to determine if the service brake is functional. These tests are not intended to measure maximum brake holding effort.

1. Start the engine, and raise the blade slightly. Engage the transmission modulator pedal and apply the service brake.



2. Move the transmission control lever to Third Speed Forward and increase the engine speed to high idle.
3. Gradually release the transmission modulator pedal. The machine should not move and the engine should stall.



## Maintenance Section

### Every 250 Service Hours or Monthly

---

#### NOTICE

If the machine begins to move, reduce the engine speed immediately and engage the parking brake.

---

**4.** Reduce the engine speed to low idle. Engage the parking brake, lower the blade to the ground and stop the engine.

---

#### NOTICE

If the machine moved while testing the brakes, contact your Caterpillar dealer. Have the dealer inspect and, if necessary, repair the service brakes before returning the machine to operation.

---

Note: If brake friction material requires replacement, the new friction material may require burnishing for maximum performance. See your Caterpillar dealer or refer to Special Instruction SEHS9580, for burnishing procedure.

### Test Parking Brake Holding Ability

#### **WARNING**

**Personal injury can result if the machine moves while testing.**

**If the machine begins to move during test, reduce the engine speed immediately and engage the parking brake.**

---

Be sure the area around machine is clear of personnel and obstructions.

Test the parking brake on a hard dry surface.

Fasten the seat belt before testing the parking brake.

The following tests are to determine if the parking brake is functional. These tests are not intended to measure maximum brake holding effort.

- 1.** Position the machine on a 20 percent slope.
- 2.** Engage the parking brake and release the service brake. The wheels should not rotate. If the wheels rotate, apply the service brake.

---

#### NOTICE

If the machine begins to move engage the service brake.

---



---

#### NOTICE

If the machine moved while testing the brakes, contact your Caterpillar dealer. Have the dealer inspect and, if necessary, repair the parking brake before returning the machine to operation.

---

## Fan and Alternator Belts

### Inspect/Adjust/Replace

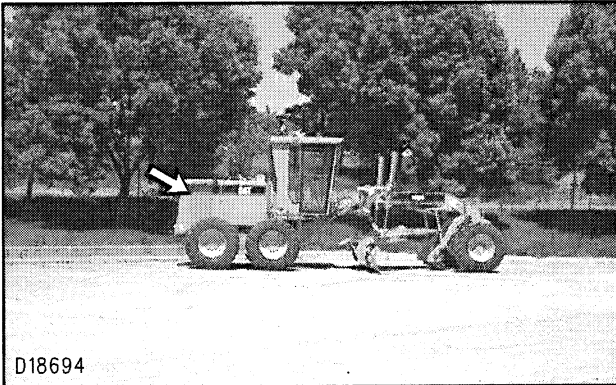

1. Open the access door on the right rear side of the machine.

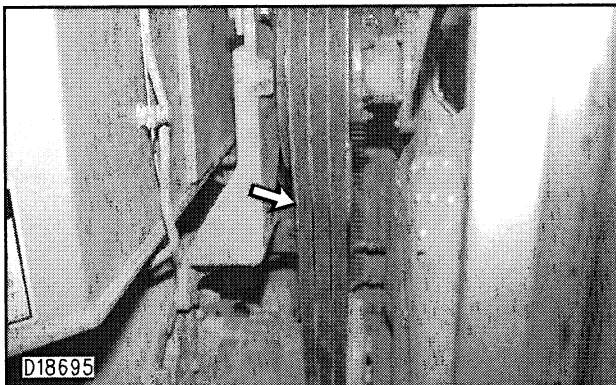

Note: Replace the belts in sets only if one or more belts are worn or damaged.

2. Inspect the condition and the adjustment of alternator belts. The belts should deflect 14 to 20 mm (.6 to .8 in) under 110 N (25 lb) force.

### Alternator Belt Adjustment

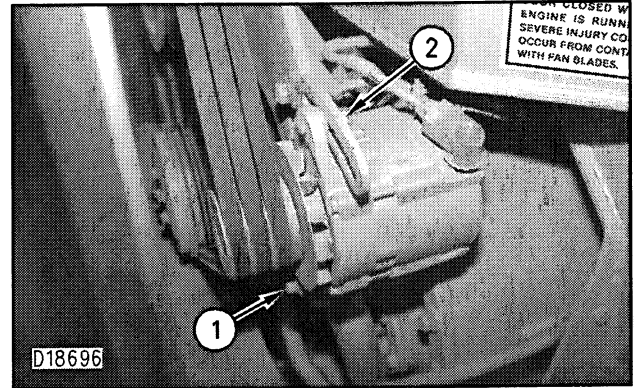

1. Loosen the alternator bracket bolt (1). Loosen the adjusting bolt (2).
2. Adjust the belts until the belt tension is reached. Tighten the adjusting bolt (2) to  $150 \pm 20 \text{ N}\cdot\text{m}$  ( $110 \pm 15 \text{ lb ft}$ ).

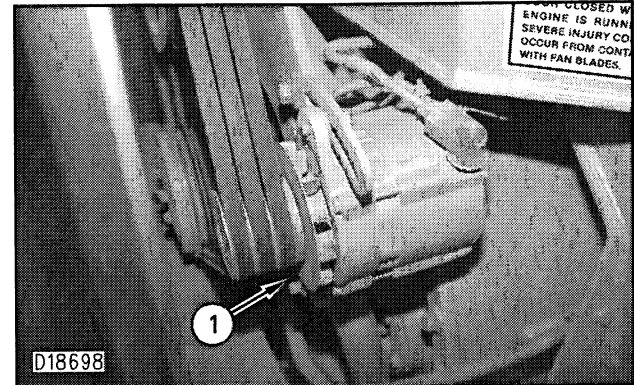

3. Tighten the alternator bracket bolt (1).
4. Close the access cover.

## Air Conditioner (If Equipped)

### Test

#### **⚠ WARNING**

Inhaling air conditioner refrigerant gas through a lit cigarette or other smoking method or inhaling fumes released from a flame contacting air conditioner refrigerant gas can cause bodily harm or death. Do not smoke when servicing air conditioners or wherever refrigerant gas may be present.

### Test Operation — Adjust Belt



1. Start the engine. Operate the engine at high idle.

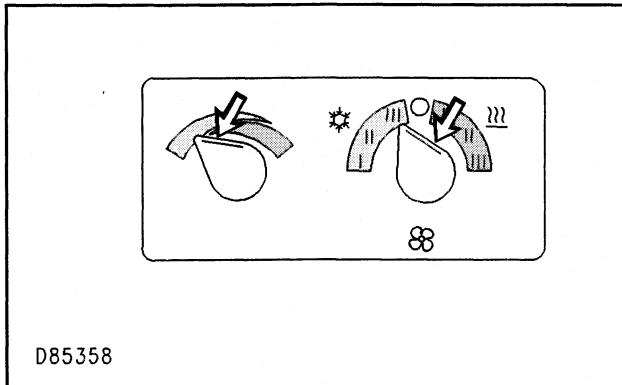

2. Set the air conditioner control for maximum cooling, and fan control on HIGH.
3. Allow two minutes for the air conditioning system to stabilize.

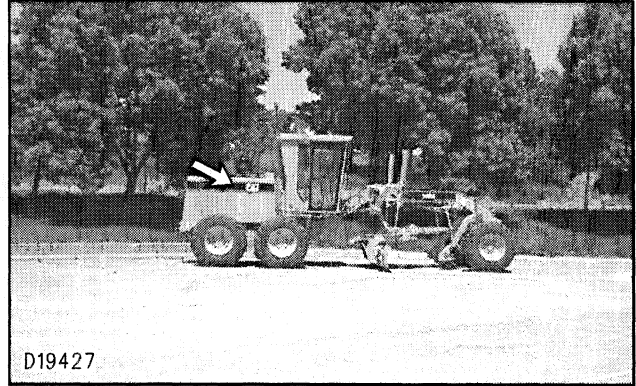

4. Open the access door on the right side of the machine.

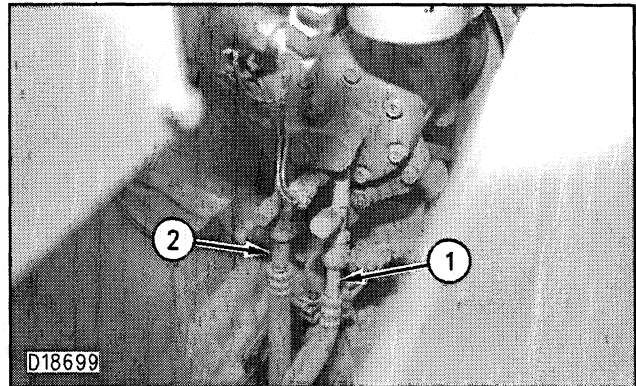

5. Check for refrigerant in the system as follows:
  - Feel the suction line (1) and the discharge line (2).
  - If the system contains refrigerant, the discharge line will be warmer than the suction line.
  - If the system does not contain, or is very low on refrigerant, poor cooling will result.
6. Stop the engine to inspect the compressor belt.

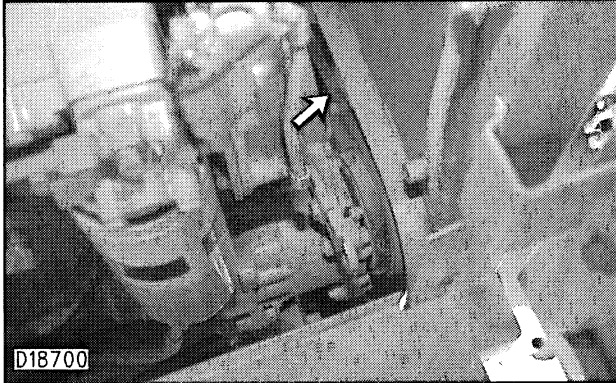

**7.** Inspect the condition and the adjustment of the compressor belt. The belt should deflect 14 to 20 mm (.6 to .8 in) under 110 N (25 lb) force.

**8.** Close the access door.

#### To Adjust

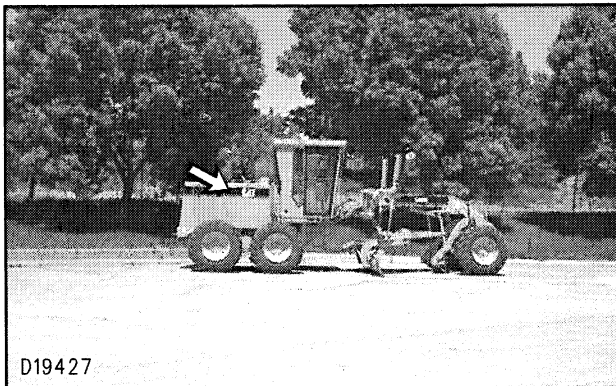

**1.** Open the access door on the right side of the machine.

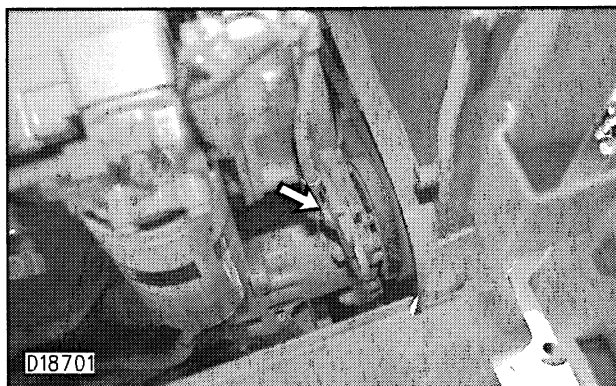

**2.** Loosen the compressor lock bolt and mounting bolt.

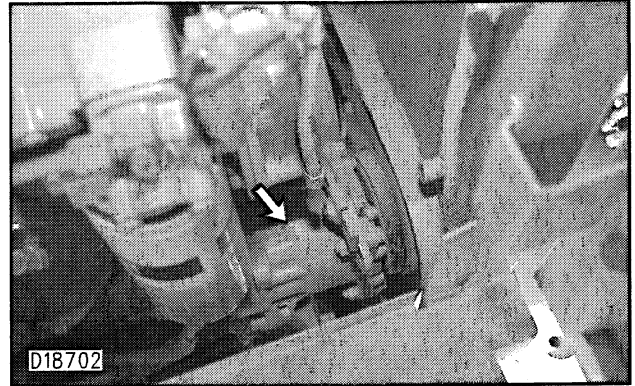

**3.** Pull the air conditioner compressor back. Tighten the mounting bolt and compressor lock bolt.

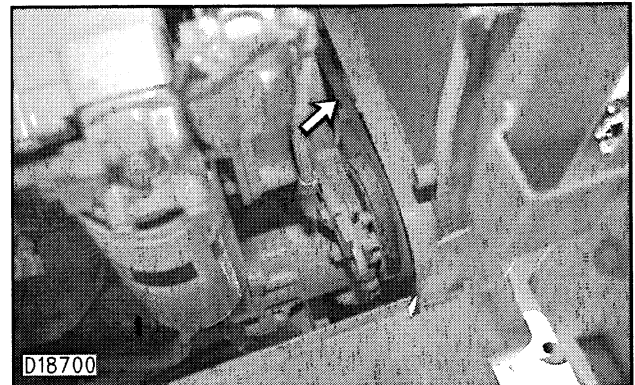

**4.** Recheck the belt adjustment.

**5.** Repeat Steps 1 through 3.

**6.** Close the access door.

**7.** If poor cooling is still experienced after starting engine, turn off the air conditioner. Stop the engine. Contact your Caterpillar dealer for air conditioner system service, if necessary.

## Air Dryer (If Equipped)

### Check for Moisture

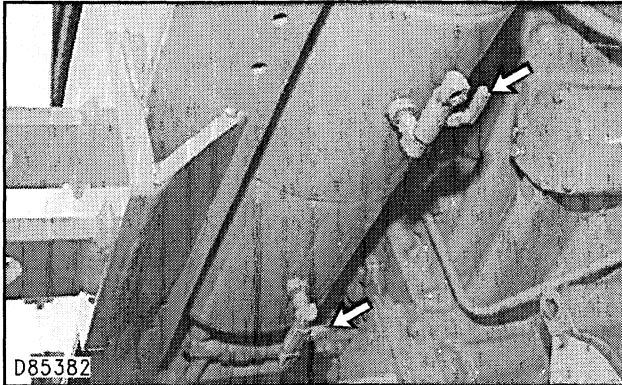

1. Open the air reservoir drain valves, one on each end of the air reservoir.
2. Check for moisture in the reservoirs. Close the drain valves.

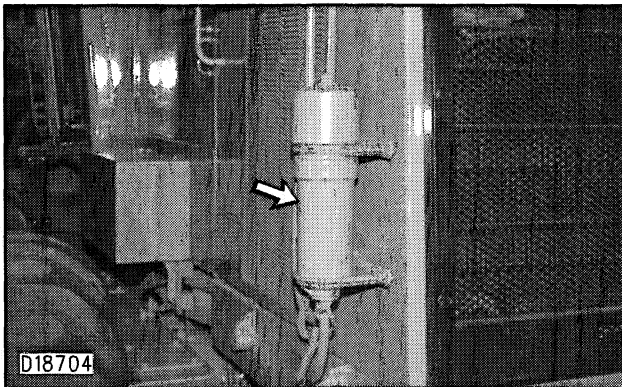

3. If moisture is present, replace or rebuild the desiccant cartridge in the air dryer. Contact your Caterpillar dealer for rebuilding instructions and replacement information.

Note: Small amounts of moisture may be present due to condensation in the system. Moisture may also be present when an air dryer has been installed on machine that had been operating without an air dryer. Several weeks may be required to completely dry the system.

## Batteries

### Check Electrolyte Level

BATTERY ELECTROLYTE CHART	
Battery	Interval
Conventional	100 Hours
Low Maintenance	250 Hours
Maintenance Free	None Required

Tighten the battery retainers every 1000 hours on all batteries.

Check the following at least every 1000 hours, and more often as conditions require:

1. Open the battery access cover located at the right front of the machine.
2. Clean the battery surface with a clean cloth.
3. Keep the terminals clean. If using corrosion protection coating, use only after the cable is connected and clean.
4. Install the post cover after coating the terminals.
5. Follow these additional instructions for conventional and low maintenance batteries:
  - Inspect the electrolyte level in each battery cell, except maintenance free.
  - Maintain the level to the bottom of the fill openings with distilled water. If distilled water is not available, use clean drinking water.
  - At the proper charging rate, in a moderate climate, a battery should not require more than 30 cc (1 ounce) of water per cell per week.
  - Check the cells weekly in extreme temperatures, cell water usage could be higher.
6. Close the access cover.

### **Replacement of Battery, Battery Cable or Disconnect Switch**

- 1.** Turn the engine start switch key to OFF. Turn all switches to the OFF position.
- 2.** Turn the battery disconnect switch key to OFF and remove the key.
- 3.** Disconnect the negative (-) battery cable, at the battery disconnect switch, that is connected to the machine frame.

Note: Do not allow the disconnected battery cable to contact the disconnect switch.

- 4.** Disconnect the negative (-) battery cable at the battery.
- 5.** Disconnect the positive (+) battery cable at the battery.
- 6.** Make necessary repairs and cable or battery replacement.
- 7.** Connect the positive (+) battery cable at the battery.
- 8.** Connect the negative (-) battery cable at the battery.
- 9.** Connect the battery cable at the battery disconnect switch.
- 10.** Install the key and turn the battery disconnect switch to ON.

### **Battery Recycling**

- 1.** A battery should always be recycled and never discarded.
- 2.** A used battery must be returned to a battery dealer or to an authorized battery collection or recycling facility.



## Every 500 Service Hours or 3 Months

*You must read and understand the warnings and instructions contained in the Safety Section of this manual, before performing any operation or maintenance procedures.*

### Transmission and Differential Oil Filter and Screens

#### Change Filter/Clean Screen



The transmission filter is located under the radiator, at the right rear of the machine.

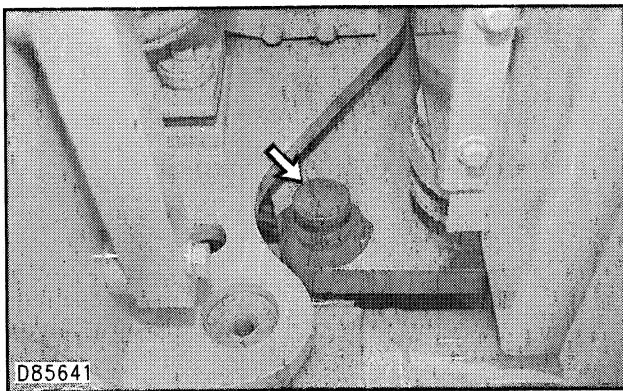

**1.** Install the frame lockpin.

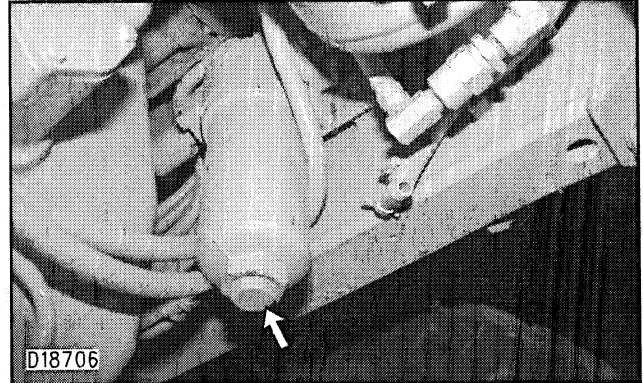

**2.** Remove the transmission filter housing drain plug. Allow the oil to drain into a container.

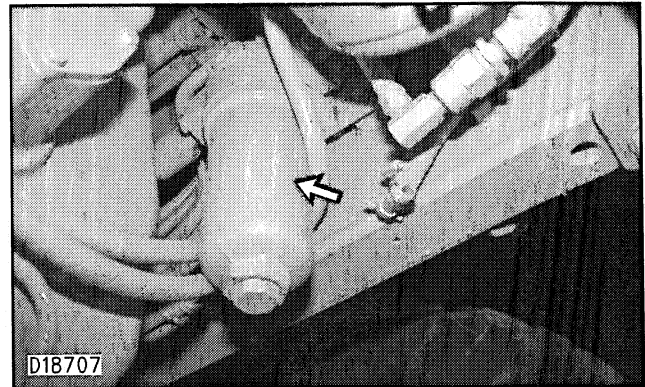

**3.** Remove the filter housing.

**4.** Remove and discard the used element.

**5.** Clean the filter housing and drain plug with a clean, nonflammable solvent.

**6.** Clean the housing base.

**7.** Insert a new filter element into the filter housing.

**8.** Inspect the filter housing seal. Replace the seal, if it is damaged.

**9.** Install the cover on the filter housing.

**10.** Install the drain plug in the filter housing.

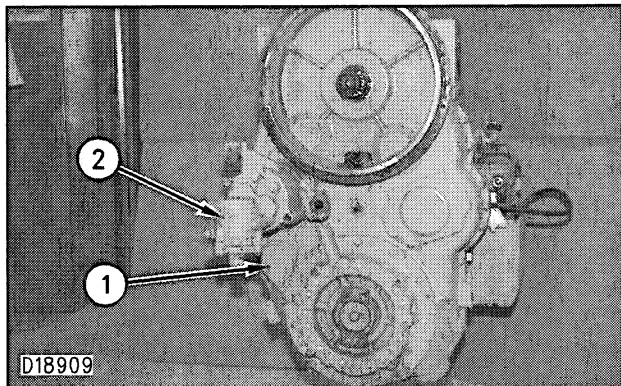

**11.** Slowly remove the magnetic screen cover (1) and the supplemental magnetic screen cover (2). Allow the oil to drain into a suitable container.

**12.** Remove the magnetic screen assemblies.

**13.** Separate the magnets and tube assemblies from screens. Wash the screens and tube assemblies in clean, nonflammable solvent. Allow the magnets and tube assemblies to dry.

---

**NOTICE**

**Do not drop or rap the magnets on hard objects or damage can result. Replace any damaged magnets.**

---

**14.** Clean the magnets with a cloth or stiff brush. Allow the magnets to dry.

**15.** Install the magnets and tube assemblies into the screens.

**16.** Install the screens.

**17.** Inspect the cover seals. Replace if damaged.

**18.** Install the covers and tighten the bolts.

**19.** Start the engine.

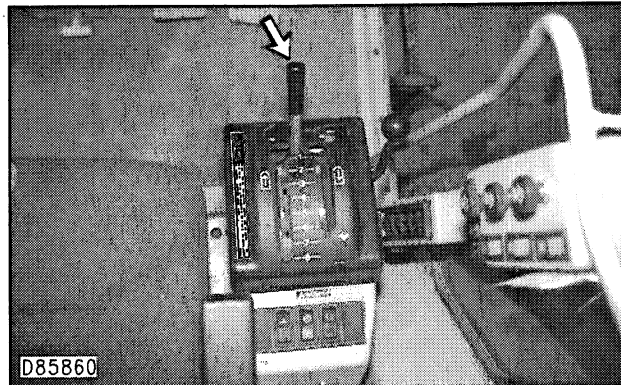

**20.** Run the engine at low idle with the parking brake engaged to circulate the transmission oil.

**21.** Inspect for leaks.

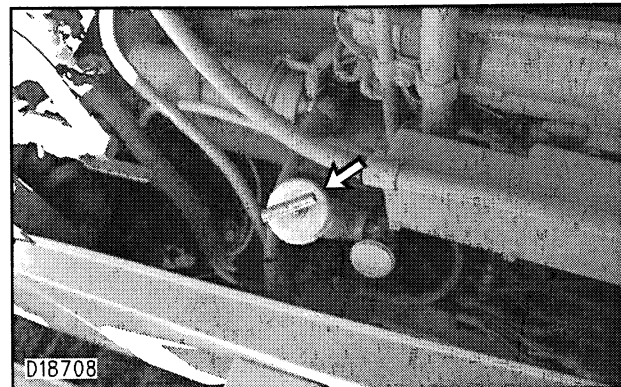

**22.** Maintain the oil level between the marks on the dipstick at Low Idle. Add the oil through fill tube if necessary.

**23.** Stop the engine.

**24.** Remove and store the frame lockpin.

## Hydraulic System

### Change Filter

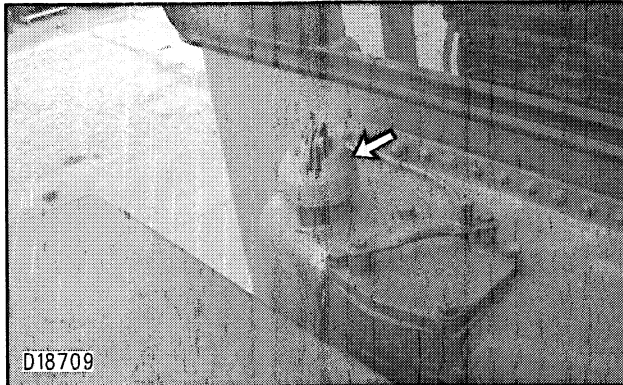

**1.** Slowly remove the oil fill cap to relieve the tank pressure before changing the filters.

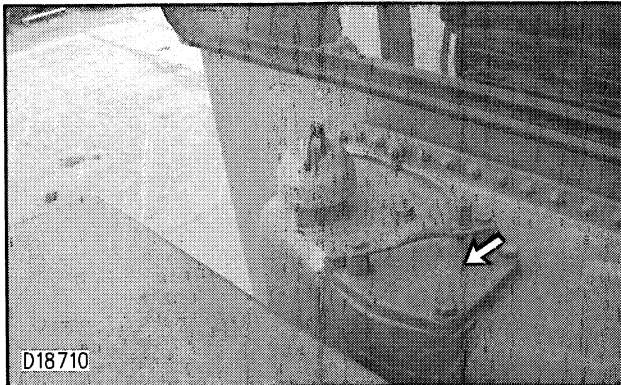

- 2.** Remove the filter cover.
- 3.** Inspect the cover seal. Replace if necessary.
- 4.** Remove and discard the filter element.
- 5.** Install the screen and a new filter element.
- 6.** Install the cover.

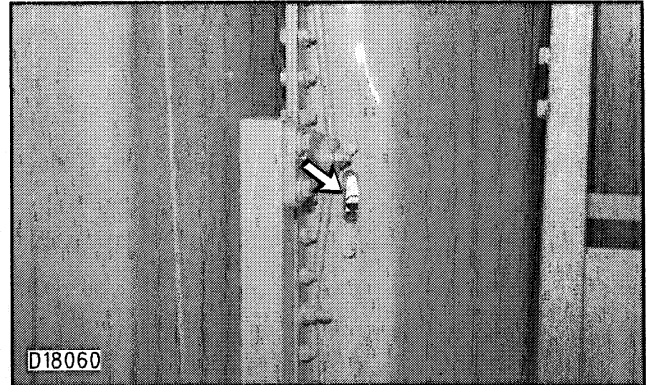

**7.** Maintain the hydraulic oil level above the ADD COLD mark in the sight gauge.

**8.** Inspect the fill cap gasket. Replace the gasket, if it is damaged. Install the oil fill cap.

## Fuel System

### Clean and Change Filters

#### NOTICE

Do not fill fuel filters with fuel before installing them. Contaminated fuel will cause accelerated wear to fuel system parts.

#### Wash the Primary Filter Element

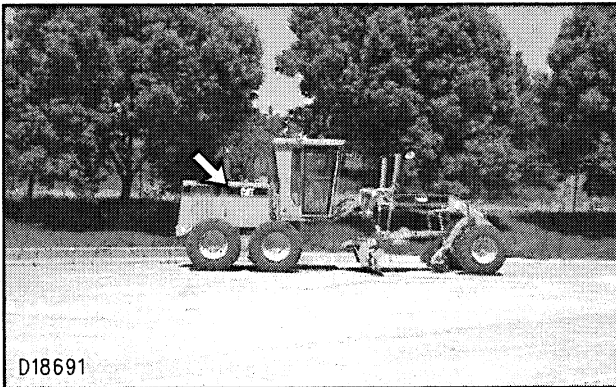

1. Open the right access door of the machine.
2. Close the fuel supply valve.

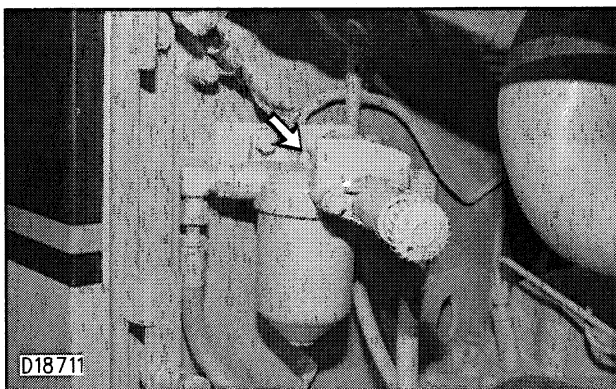

3. Loosen the filter housing retaining bolt.
4. Remove the housing and element.
5. Remove the element from the case.

6. Wash the element and housing in clean, nonflammable solvent.
7. Dry the element using pressure air.
8. Clean the filter case.
9. Inspect the seal. Replace if damaged.
10. Insert the clean element.
11. Install the element and the case into the housing.
12. Tighten the retaining bolt to a torque of  $24 \pm 4 \text{ N}\cdot\text{m}$  ( $18 \pm 3 \text{ lb ft}$ ).

#### Change Secondary Fuel Filter

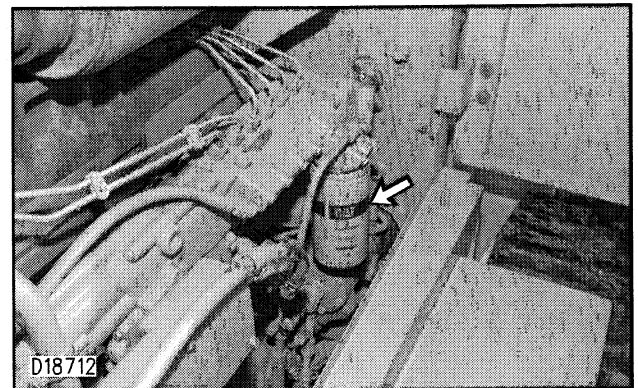

1. Remove and discard the filter.
2. Clean the filter mounting base. Be sure all of the old seal is removed.
3. Coat the seal of a new filter with clean diesel fuel.
4. Install the new filter by hand. When the seal contacts the base, tighten an additional three quarters of a turn.

There are rotation index marks 90 degrees apart on the filter. Use them as a guide for proper tightening.

5. Open the fuel supply valve.
6. Prime the fuel system. (See next topic).

## Fuel Priming Pump

### Filters and Pump Housing

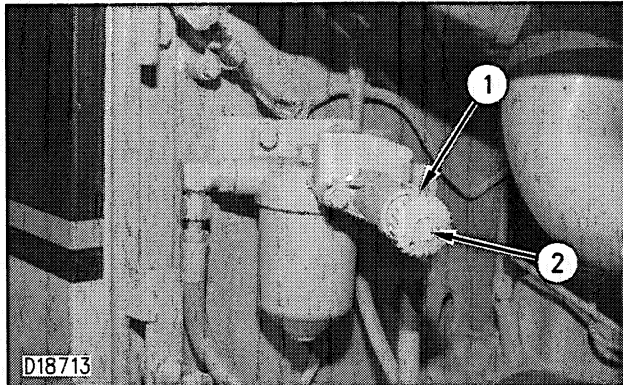

1. Open the fuel system purge valve (1) on the pump housing.
2. Unlock the priming pump plunger (2) and operate the pump.
3. When fuel flows free of air bubbles, close the pump and lock the plunger.
4. Close the purge valve.
5. Start the engine and check for leaks.
6. Close the access cover.

## Fuel Tank Cap and Fill Screen

### Clean



The fuel cap is located on the left rear top of the machine.

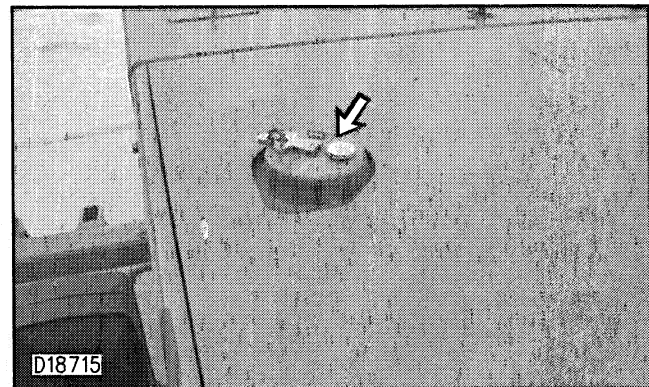

1. Remove and disassemble the cap.
2. Inspect the gasket for damage. Replace the gasket if necessary.
3. Remove the strainer and dipstick from the fill opening.
4. Wash the strainer, cap and cap element in clean, nonflammable solvent.
5. Install the strainer and dipstick.
6. Lightly oil the element and assemble the fuel cap.
7. Install the fuel cap.



## Engine Crankcase Breather

### Clean Breather



Open the access door located on the left side of the machine.



**1.** Loosen the breather outlet hose clamp and remove the hose from the breather cover.

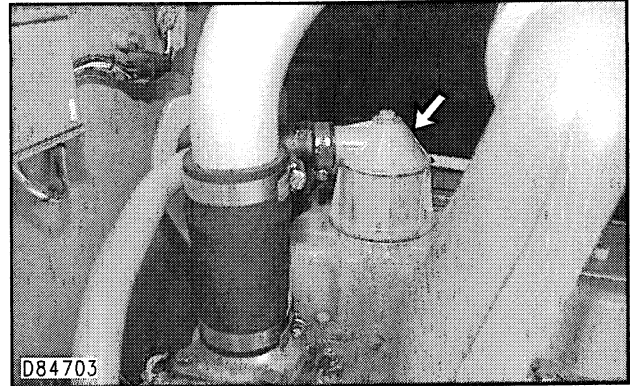

- 2.** Remove the breather bolt and remove the breather.
- 3.** Check the condition of cover seal. Replace with a new seal if damaged.
- 4.** Wash the element and cover assembly in clean, nonflammable solvent.
- 5.** Shake, or use pressure air, to dry the element.
- 6.** Inspect the hose for damage. Replace if necessary.
- 7.** Install the breather element cover assembly.
- 8.** Install the hose and the clamp.



**9.** Close the access door.



## Hydraulic Pump Driveshaft

### Lubricate Fitting

Wipe the fitting before lubricating.

Note: Articulate the front of the machine to the right for improved access to the fitting.

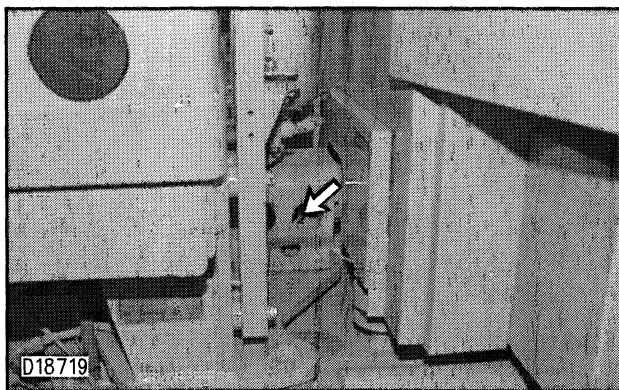

Lubricate one fitting on the hydraulic pump driveshaft.

## Front Wheel Spindle Bearings

### Check the Oil Level

Clean the surface area around the level/fill plug before checking the oil level.

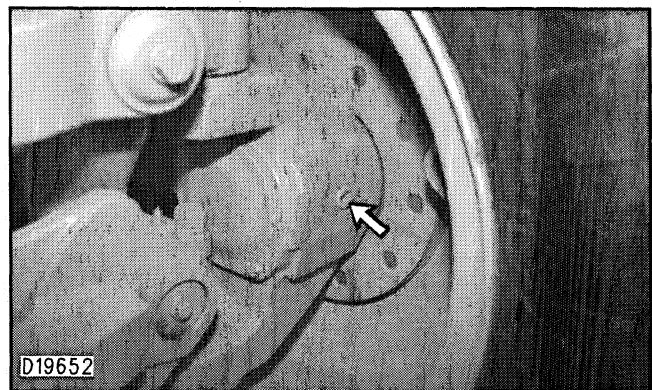
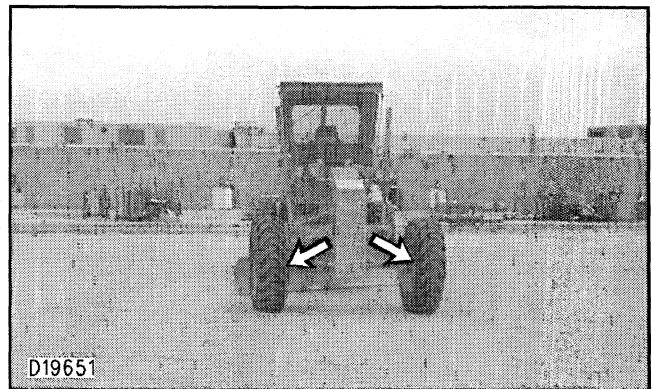

1. Remove the level/fill plug.
2. Maintain the oil level to the bottom of the level/fill plug opening. If the oil level is low, inspect the front wheel spindle bearing housing for leaks.

If a leak is found contact your Caterpillar dealer for inspection and, if necessary, repairs.

If no leak is found, add oil.

3. Install the level/fill plug.
4. Repeat Steps 1 through 3 for the other front wheel spindle bearing.

## Every 1000 Service Hours or 6 Months

*You must read and understand the warnings and instructions contained in the Safety Section of this manual, before performing any operation or maintenance procedures.*

### Transmission and Differential Oil

#### Change the Oil

Operate the engine long enough to warm the oil. The machine must be level. Lower the blade with slight down pressure.

Engage the parking brake. Stop the engine.

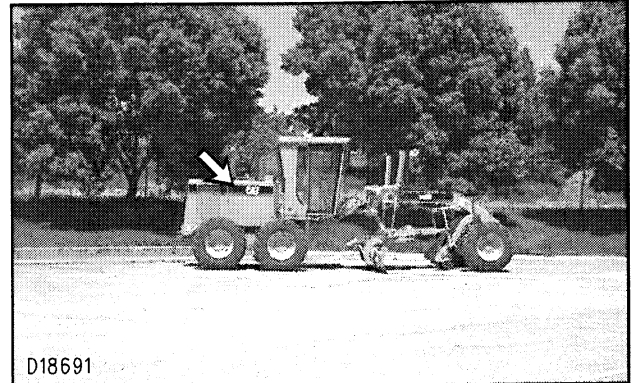

4. Open the right side access door.



1. Remove the drain plugs for the differential and transmission case. Drain the oil into a suitable container.
2. Change the filter element and clean the screens. See the topic Transmission Oil Filter under Every 500 Service Hours or 3 Months.
3. Clean and install the drain plugs for the differential and transmission case drain plugs.

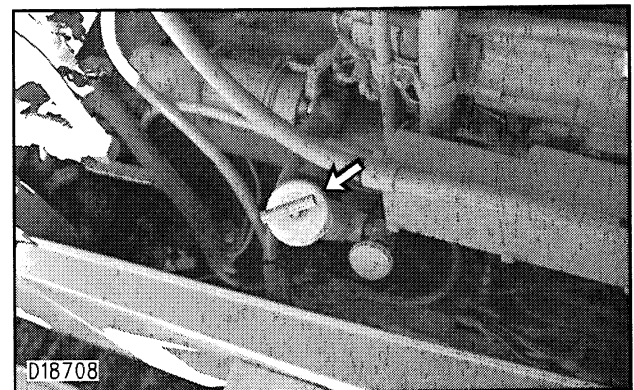

5. Fill the transmission with oil through the fill tube. See the Lubricant Viscosities and Refill Capacities chart.

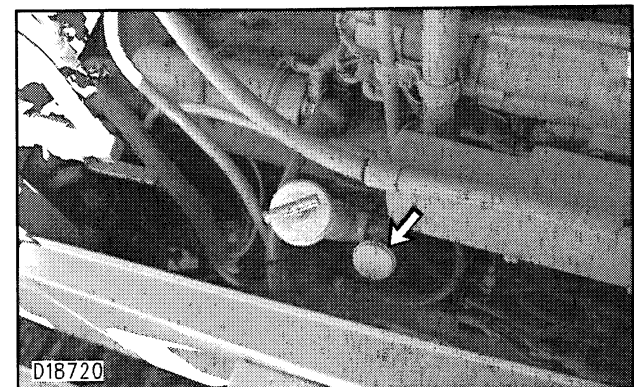

6. Remove the transmission breather. Install a new transmission breather.

**164**  
**Maintenance Section**  
**Every 1000 Service Hours or 6 Months**

- 7.** Close the access door.
- 8.** Start and run the engine at low idle. Inspect for leaks.
- 9.** Engage the transmission modulation pedal and slowly operate the transmission control lever to circulate the oil.

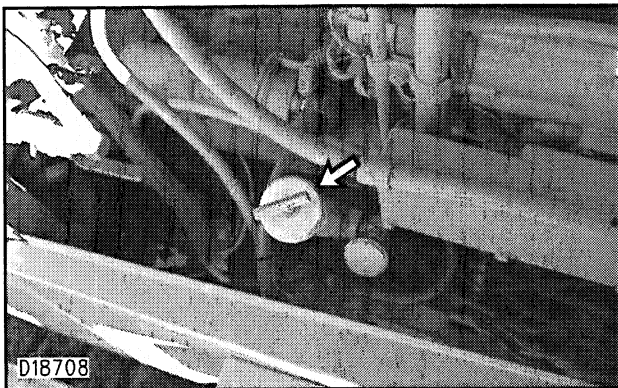

- 10.** Maintain the oil level between the marks on dipstick at LOW IDLE. Add the oil through fill tube if necessary.
- 11.** Stop the engine.

## **Rollover Protective Structure (ROPS)**

### **Inspect**



- 1.** Remove the access covers.

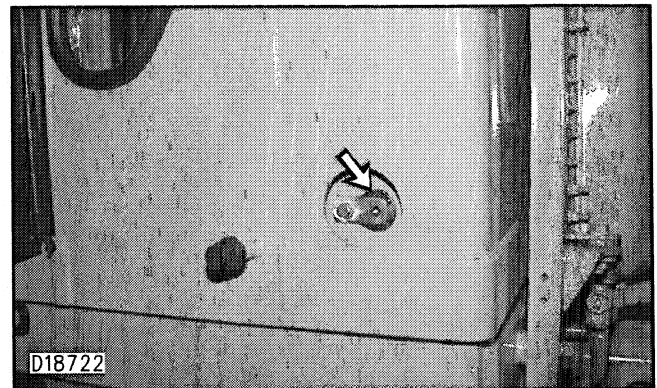

- 2.** Inspect the retaining pins. Inspect the keeper bolt . Replace damaged bolts or missing bolts with original equipment parts only.
- 3.** Install the access covers.

4. Inspect for any loose or damaged bolts. Replace damaged bolts or missing bolts with original equipment parts only. Tighten the rear bolts to a torque of  $475 \pm 60 \text{ N}\cdot\text{m}$  ( $350 \pm 45 \text{ lb ft}$ ). Tighten the front bolts to a torque of  $270 \pm 40 \text{ N}\cdot\text{m}$  ( $200 \pm 30 \text{ lb ft}$ ).

Note: Apply oil to all ROPS bolt threads before installing. Failure to apply oil can result in improper bolt torque.

5. Replace ROPS mounting supports if the ROPS rattles or makes a noise when the machine is operated on a rough surface.

Do not straighten or repair by welding reinforcement plates to the ROPS.

Contact your Caterpillar dealer for repair of cracks in welds, castings or any metal section on the ROPS.

## Air Dryer (If Equipped)

### Change Dessicant

#### **WARNING**

**Air lines to and from the air dryer must be at atmospheric pressure. Release the air pressure from the air system completely before performing maintenance.**

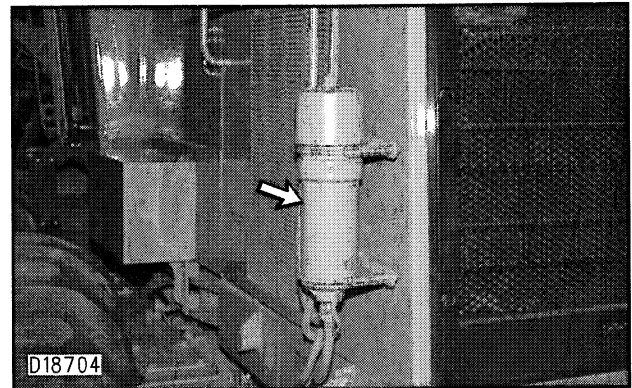
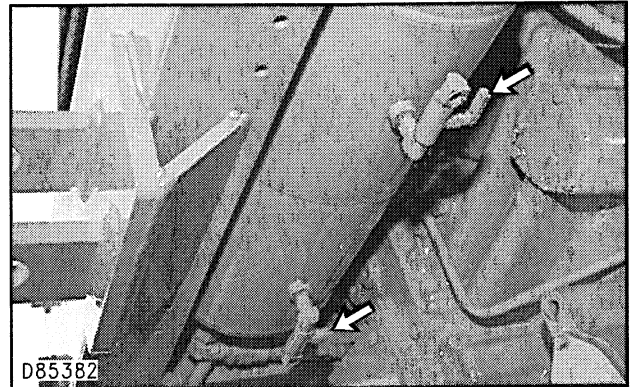

Replace or rebuild the desiccant cartridge if water can no longer be absorbed. Consult your Caterpillar dealer for service or replacement parts.

## Every 2000 Service Hours or 1 Year

*You must read and understand the warnings and instructions contained in the Safety Section of this manual, before performing any operation or maintenance procedures.*

### Hydraulic System Oil

#### Change the Oil

Operate the machine long enough to warm the oil.

The machine should be level. All equipment should be lowered to the ground with a slight down pressure. The parking brake should be engaged, and the engine stopped.

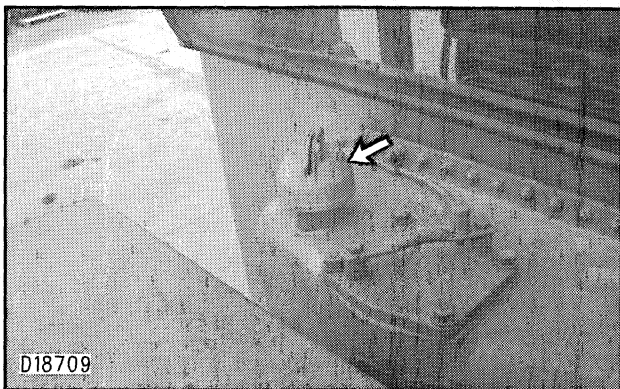
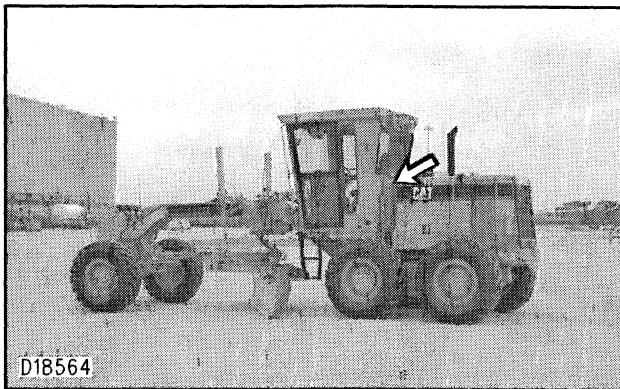

1. Slowly remove the hydraulic system oil tank fill cap.

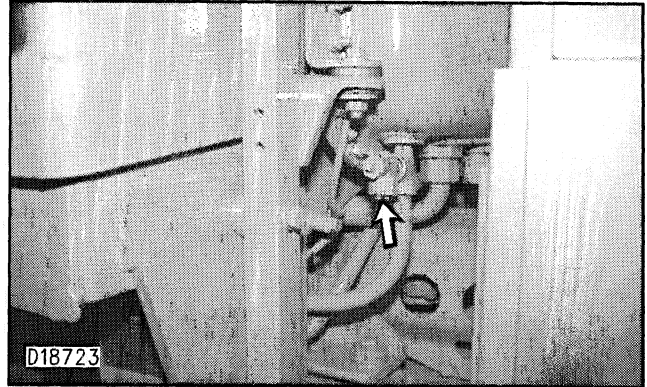

2. Remove the drain plug located in the bottom of the hydraulic tank. Drain the oil into a suitable container.
3. Change the hydraulic system filter. See Hydraulic System in the Every 500 Service Hours or 3 Months Section.
4. Remove the fill screen. Wash in clean, nonflammable solvent. Allow to dry.
5. Clean and install the drain plug.
6. Install the fill screen.
7. Fill the hydraulic system oil tank. See Lubricant Viscosities and Refill Capacities.
8. Inspect the fill cap gasket. Replace the gasket if damaged.
9. Install the oil fill cap.
10. Start and run the engine for a few minutes.

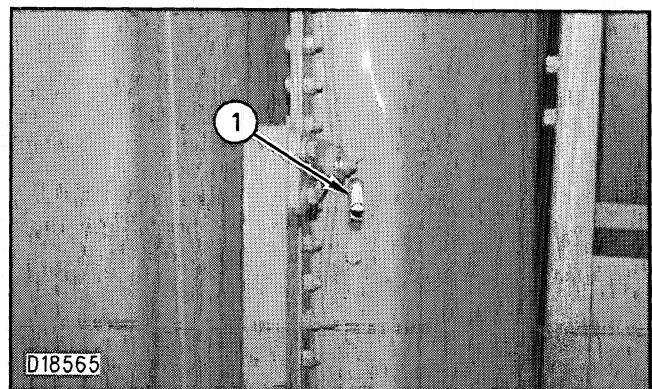



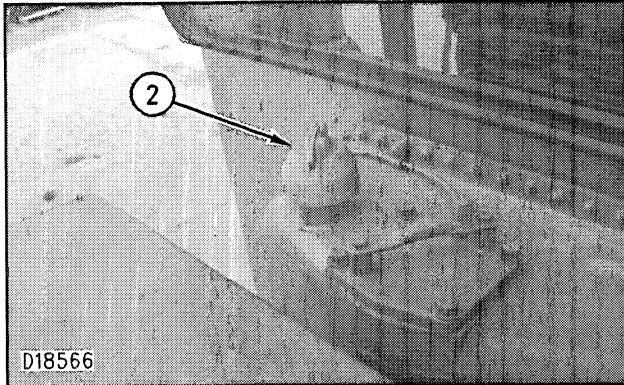

**11.** Maintain the oil level above the ADD COLD mark in the sight gauge (1). Add oil through the fill tube (2), if necessary.

Note: The oil must be free of bubbles. If bubbles are present in the oil, air is entering the hydraulic system. Inspect the suction line hoses and clamps.

**12.** Stop the engine.

**13.** If necessary, tighten any loose clamps and connections. Replace any damaged hoses.

## Tandem Drive Housing Oil

### Change the Oil

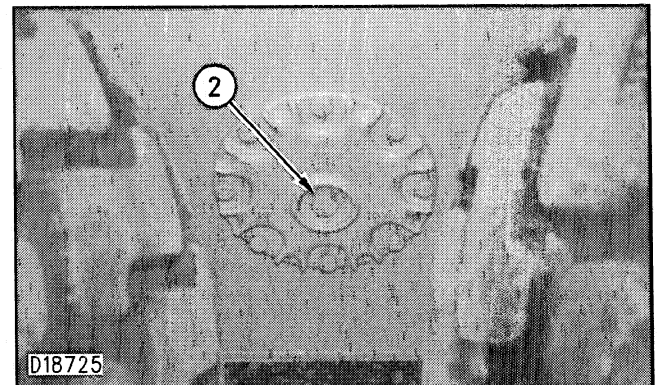
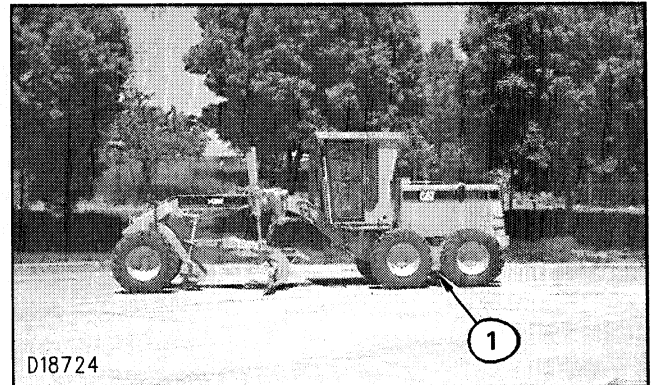

- 1.** Remove the drain plug (1) and the level/fill plug (2). Allow the oil to drain into a suitable container.
- 2.** Clean and install the drain plug.
- 3.** Fill the tandem drive housing with oil. See Lubricant Viscosities and Refill Capacities.
- 4.** Install the level/fill plug.
- 5.** Start the engine and operate the machine for a few minutes. Check for leaks.



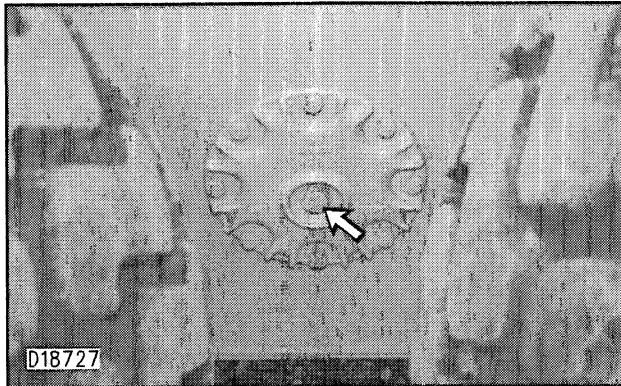

**6.** Stop the engine. Remove the level/fill plug and check the oil level. Maintain the oil level to the bottom of the fill opening. Add oil if necessary.

## Circle Drive Housing

### Change the Oil

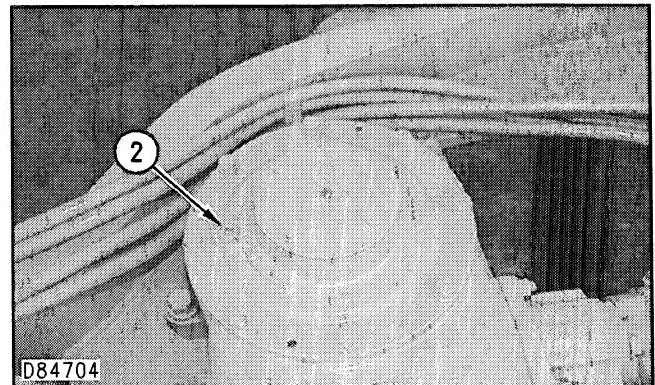
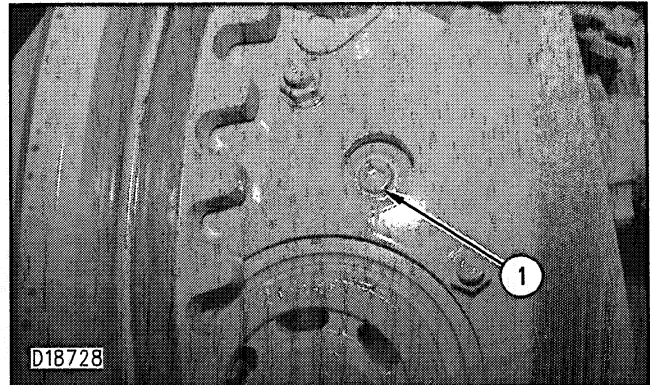

- 1.** Remove the drain plug (1) and the level/fill plug (2). Allow the oil to drain into a suitable container.
- 2.** Clean and install the drain plug.
- 3.** Fill the circle drive housing with oil. See Lubricant Viscosities and Refill Capacities.
- 4.** Install the level/fill plug.
- 5.** Start the engine and operate the machine for a few minutes. Check for leaks.
- 6.** Stop the engine. Remove the level/fill plug and check the oil level. Maintain the oil level to the bottom of the fill opening. Add oil if necessary.

## Engine Valve Lash

### Adjust

Note: Have a qualified service person to check and adjust the fuel injector timing. Special tools and training are required.

Refer to the Service Manual for the complete procedure.

Note: The correct fuel timing specification is given on the Engine Information Plate. Fuel timing specification may be different for engines with different applications and/or power ratings.

Refer to the Service Manual or your Caterpillar dealer for the complete adjustment procedure.

## Engine Valve Rotators

### Check

### **WARNING**

**When inspecting the valve rotators, protective glasses or face shield and protective clothing must be worn, to prevent being burned by hot oil spray.**

1. Start the engine and run at Low Idle.
2. Watch the top surface on each valve rotator. Each valve rotator should turn slightly each time the valve closes.

If a valve fails to rotate, contact your Caterpillar dealer.

## Every 3000 Service Hours or 2 Years

*You must read and understand the warnings and instructions contained in the Safety Section of this manual, before performing any operation or maintenance procedures.*

### Cooling System Coolant

#### Add Extender

For cooling system equipped with Caterpillar's Long Life Coolant/Antifreeze the addition of Extender will allow the changing and cleaning interval to be extended to 6000 Service Hours or 4 Years.

Refer to the Cooling System Specifications Section of this manual for all cooling system requirements.

---

#### NOTICE

**Excessive additive (greater than the recommended 6% initial fill) together with concentrations of antifreeze greater than 60% cause deposits to form and can result in radiator tube blockage and overheating.**

---

### Change the Coolant/Clean the System

---

#### NOTICE

**Do not change the coolant until you read and understand the material in the Cooling System Specifications Section.**

---

Drain the coolant earlier whenever the coolant is dirty or foaming is observed.



The radiator cap is located in the top of the hood.

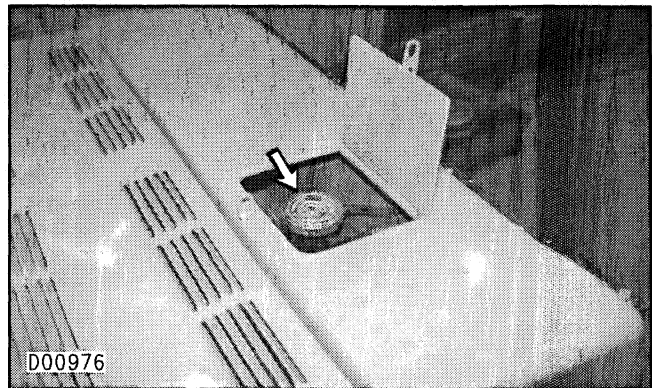

1. Open the access door and remove the radiator cap slowly to relieve pressure.



- 2.** Open the drain valve and remove the drain plug. Allow the coolant to drain into a suitable container. The drain valve is located under the radiator and the drain plug is located on the lower engine water line.
- 3.** Install the drain plug and close the drain valve. Fill the system with clean water and a 6 to 10% concentration of cooling system cleaner.
- 4.** Start and run the engine for 90 minutes. Stop the engine and drain the cleaning solution.
- 5.** Flush the system with water, with the engine stopped, until the draining water is clear.
- 6.** Install the drain plug and close the drain valve.
- 7.** Add the coolant solution. See Cooling System Specifications and Lubricant Viscosities and Refill Capacities.

Note: Do not add supplemental coolant additive or change element at this time, unless you are not using Caterpillar Antifreeze which contains additive.

- 8.** Start the engine and operate it with the radiator cap off until the thermostat opens and the level stabilizes.
- 9.** Maintain the coolant level to within 13 mm (.5 in) of the bottom of the fill pipe.
- 10.** Install the cap.
- 11.** Stop the engine.

### Clean Outside of Radiator Fins



Compressed air is preferred, but high pressure water or steam can be used to remove dust, leaves and general debris from radiator fins.