

SAFETY.CAT.COM™

MAINTENANCE INTERVALS

Operation and Maintenance
Manual Excerpt

Operation & Maintenance Manual

RR-250B Road Reclaimer SS-250B Soil Stabilizer

5GR1-UP

3RR1-UP

Maintenance Intervals

When Required

Engine Air Intake System - Service filters.....	67
Rotor Clutch - Adjust	69
Cooling System - Replace coolant if dirty	69
Circuit Breakers - Reset	69
Cab Circuit Breakers (If Equipped) - Reset.....	70
Filter Inspection - Inspect used filter for debris.....	70
Engine - Restart To prevent damage	71

Every 10 Service Hours or Daily

Engine - Check oil level.....	72
Hydraulic System - Check oil level	72
Radiator - Check coolant level/clean core	73
Hydraulic Oil Cooler - Inspect/clean core	73
Bearing Reservoir - Check oil level	74
Tires - Check inflation/wear.....	74
Rotor Bits and Bit Holders - Check/inspect.....	75
Seatbelt - Inspect.....	76
Walk-Around Inspection - Inspect machine.....	77
Indicators and Gauges - Test	78
Back-up Alarm - Test.....	78
Air Tanks - Drain	79

Initial 25 Service Hours

Propel System Suction Filter - Change	80
Auxiliary Return Filter - Change.....	80

Initial 50 Service Hours

Rotor Clutch Lever - Check force required to engage	81
--	----

Every 50 Service Hours or Weekly *

Propel Axle & Planetary Ends - Check oil levels.....	82
Propel Axle Gearbox - Check oil levels	82
Rotor Transmission Drive Oil - Check oil level	83
Rotor Chaincase - Check oil level.....	83
Rotor Drive Shafts - Lubricate.....	84
Hood Cylinder - Lubricate.....	84
Hood Torque Tube - Lubricate	85
Chaincase Shaft Bearings - Lubricate.....	85
Chaincase Lift Cylinders - Lubricate	86
Rear Leg Pivot Pins - Lubricate	86
Rear Steer Cylinder - Lubricate.....	87
Chaincase Supports - Lubricate.....	87
Engine Air System - Check.....	88
Fuel Tank - Drain water and sediment.....	88
Axle Tie Rod and Steer Cylinder - Lubricate	89
Shear Disc Bushing - Lubricate	89

Depth Gauge Pivot - Lubricate	90
Rotor Axle - Check Level.....	90

Every 125 Service Hours or 2 Weeks *

Pump Drive Shaft - Lubricate	91
Rotor Clutch Collar, Bearings & Release Lever - Lubricate	91
Rotor Torque Limiter - Check wear indicator.....	92

Every 250 Service Hours or Monthly *

Propel System Suction Filter - Change	93
Auxiliary Return Filter - Change.....	93
Engine Oil and Filters - Change	94
Engine Valve Lash - Adjust on new or recon engines at first oil change only	95
Cooling System - Change coolant additive element	95
Belts - Inspect/adjust	96
Fan Bearing - Lubricate.....	98
Propel Axle U-Joints - Lubricate	98
Batteries - Inspect	98

Every 500 Service Hours or 3 Months *

Fuel System - Clean/change filters.....	100
Fuel Tank Cap And Fill Screen - Clean.....	101
Hydraulic System - Change oil and filters.....	102
Propel Axle/Propel Axle Gearbox - Change oil.....	102
Rotor Chaincase - Change oil.....	103
Propel Axle Planetary Ends - Change Oil	103
Rotor Axle - Change oil	104
Rotor Transmission - Change Oil	104

Every 1000 Service Hours or 6 Months *

Rotor Transmission Shift Linkage - Lubricate	105
Rear Wheel Hub Bearings - Lubricate	105
Propel Transmission Linkage - Lubricate.....	105
Rollover Protective Structure (ROPS) - Inspect...106	

Every 2000 Service Hours or 1 Year *

Engine Valve Lash - Adjust	107
Engine Valve Rotators - Check	107

Every 3000 Service Hours or 2 Years *

Cooling System Coolant - Change.....	108
---	-----

* First Perform Previous Service Hours Items

When Required

You must read and understand the warnings and instructions contained in the Safety Section of this manual, before performing any operation or maintenance procedures.

Engine Air Intake System

Clean the Air Intake

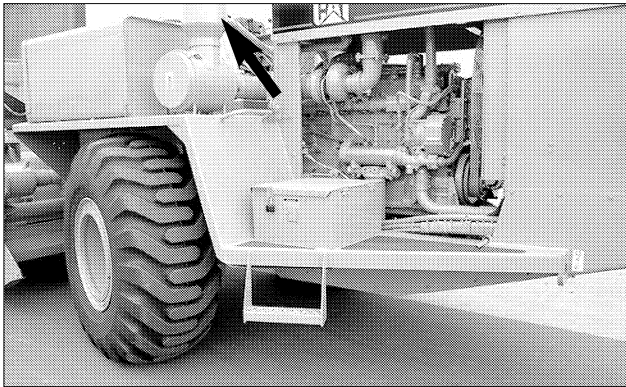

Check the air inlet hood screen for accumulation of trash and dirt.

Remove the screen if dirty, clean with pressure air and install the screen.

Service the Filter Elements

NOTICE

Service the air cleaner only with the engine stopped. Engine damage could result.

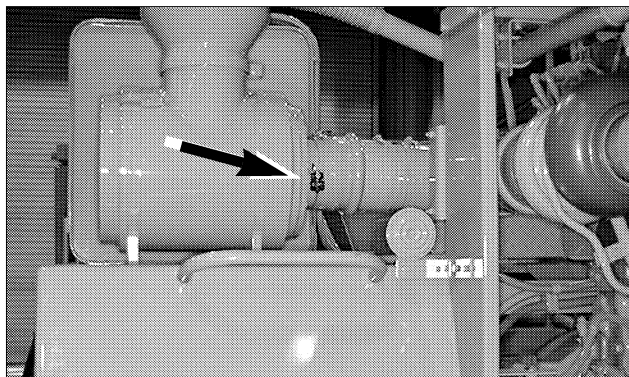

Service the air cleaner if the yellow piston in the filter element indicator moves into the red zone with the engine running at high idle. Stop the engine.

Service the Primary Element

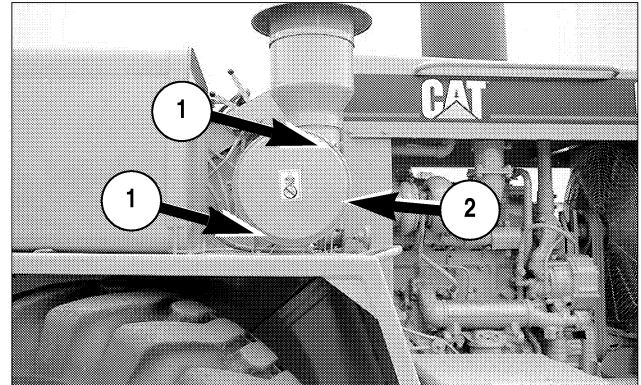

1. Loosen fasteners (1), cover (2) and the primary element.
2. Clean the inside of the air cleaner housing.
3. Clean and inspect the primary element. See Cleaning Primary Elements.
4. Install a clean primary element.
5. Clean and install cover (2). Attach fasteners (1).

If the yellow piston in the filter element indicator moves into the red zone after starting the engine, or the exhaust smoke is still black after installation of a clean primary filter element, install a new primary filter element.

The primary element should be replaced after being cleaned a maximum of six times. Replace the element once a year even though it has not been cleaned six times.

Change the Secondary Element

NOTICE

Always replace the secondary filter element. Never attempt to reuse it by cleaning.

The secondary filter element should be replaced at the time the primary element is serviced for the third time.

The secondary filter element should also be replaced if the yellow piston in the filter element indicator enters the red zone after installation of a clean primary element, or if the exhaust smoke is still black.

1. Remove the cover and the primary element.

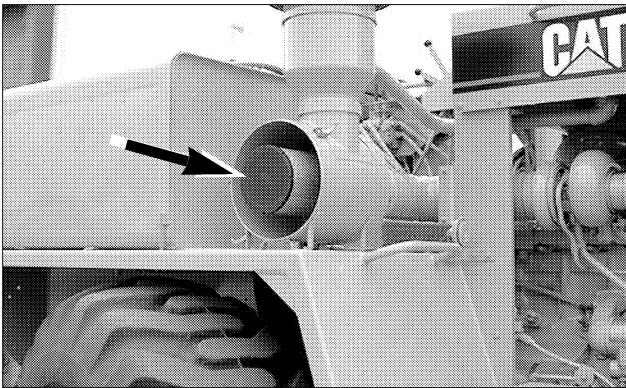

2. Remove the secondary element.
3. Cover the air inlet opening. Clean the inside of the air cleaner housing.
4. Clean out any dust or debris in the filter outlet.
5. Uncover the air inlet opening. Install a new secondary element.
6. Install the primary element and cover.

Cleaning Primary Elements

NOTICE

Do not clean the filter elements by bumping or tapping them. Do not use filter elements with damaged pleats, gaskets or seals. Engine damage can result.

Make sure the cleaned filter elements are completely dry before installing into the filter housing. Water remaining in the elements can cause false indications of contamination in Scheduled Oil Sampling test results.

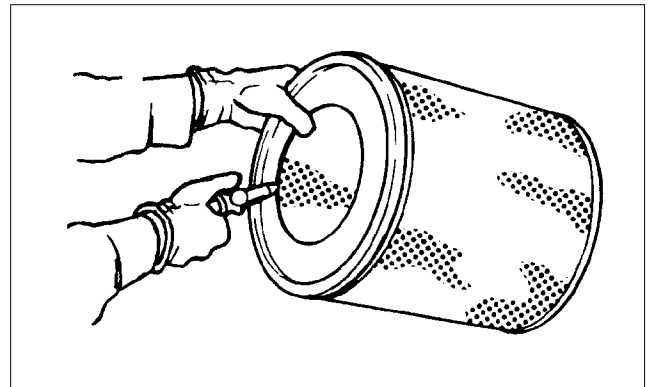

Filter elements can be cleaned with pressure air - 205 kPa (30 psi) maximum, pressure water - 280 kPa (40 psi) maximum, or detergent washing.

1. Direct air or water along the pleats inside and outside of filter element.

The element can be washed in warm water and non-sudsing household detergent. Rinse inside and outside the pleats and air dry fully.

2. Inspect the filter elements after cleaning. Do not use a filter element with damaged pleats, gaskets or seals.
3. Wrap and store the clean filter elements in a clean, dry place.

Rotor Clutch

Adjust

Refer to: "Rotor Clutch Bearing Adjustment", in the Service Manual (Form No. KENR2967, Vehicle Systems, Systems Operation, Testing & Adjusting), for the proper adjustment procedure.

Cooling System

Replace Coolant If Dirty

See "Every 3000 Service Hours or 2 Years".

Circuit Breakers

Reset



A junction box is located beneath the operator's control panel.

Circuit Breaker Reset - Push the button in to reset the circuit breakers. If working properly, button will stay depressed. If the button does not stay in, or comes out shortly after being reset, have appropriate electrical circuit checked.

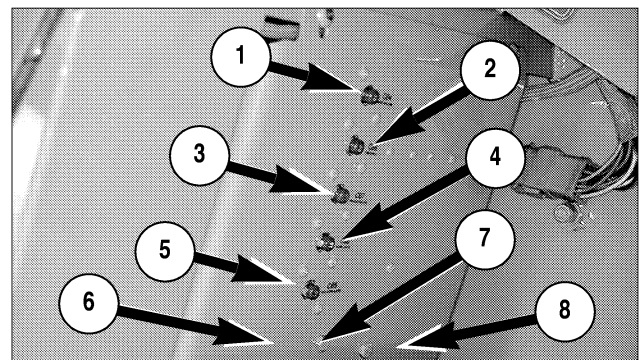

Basic Machine CB4 (1) - 15 amps.

Cab CB6 (2) - 30 amps.

FPM, Additive System CB7 (3) - 10 amps.

Work Lights CB8 (4) - 15 amps.

Fuel/Horn/Alarm CB5 (5) - 10 amps.

Alternator (6) - 80 amps.

Main (7) - 80 amps. **Engine Start (8)** - 10 amps.

Cab Circuit Breakers (If Equipped)

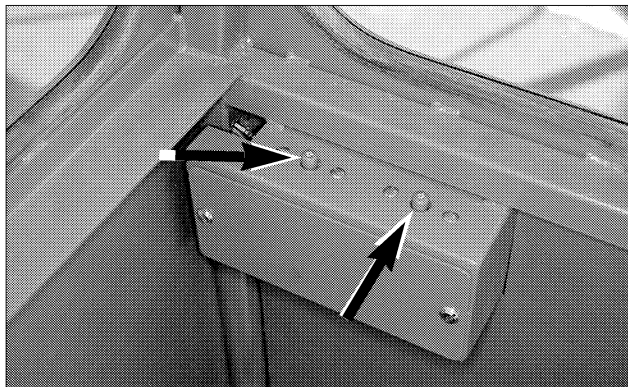

Windshield Wiper - 15 amps.

Fan - 15 amps.

Filter Inspection

Inspect Used Filter for Debris

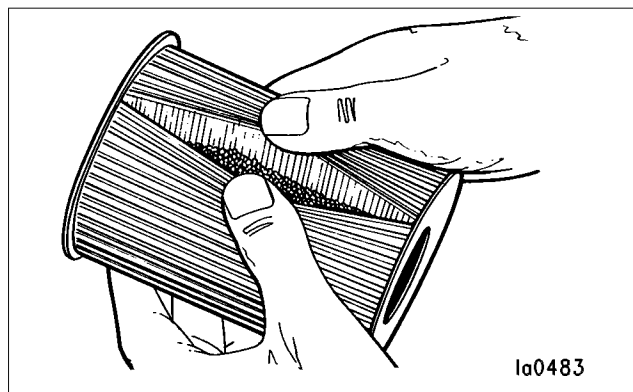

Element with debris

Use a 4C-5084 Filter Cutter (formerly 6V-7905) to cut the filter element open. Spread pleats apart and inspect the element for metal and other debris. An excessive amount of debris in the filter element can indicate a possible failure.

Use a magnet to differentiate between ferrous and non-ferrous metals found in the filter element.

Ferrous metals can indicate wear on the steel and cast iron parts.

Non-ferrous metals can indicate wear on the aluminum parts of the engine, such as main, rod and/or turbocharger bearings.

Due to normal wear and friction, it is not uncommon to find small amounts of debris in the filter element. Consult your Caterpillar dealer to arrange for further analysis if an excessive amount of debris is found.

Use of an oil filter element not recommended by Caterpillar can result in severe engine damage to engine bearings, crankshaft and other parts. This can result in larger particles in unfiltered oil entering the lubricating system and causing damage.

Restart Engine (For machines with rotor torque limiter)

NOTICE

Failure to restart engine after a stall from hitting a hard object can result in damage to the turbocharger.

When the machine is equipped with the rotor torque limiter be sure the engine is restarted immediately after an object is struck hard enough to stall the engine. If the engine is not restarted immediately, damage to the turbocharger can result.

Every 10 Service Hours or Daily

You must read and understand the warnings and instructions contained in the Safety Section of this manual, before performing any operation or maintenance procedures.

Engine

Check Oil Level

NOTICE

Do not overfill the crankcase. Engine damage can result.

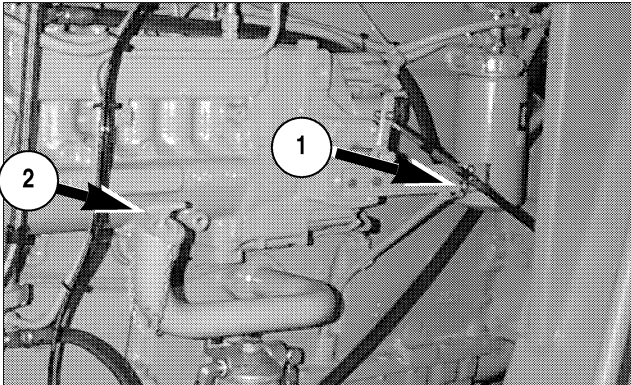

1. With the engine stopped, maintain the oil level between the "L" and the "F" marks on the ENGINE STOPPED side of dipstick (1).

With the engine running, maintain the oil level between the "L" and the "F" marks on the LOW IDLE side of dipstick (1).

2. Remove oil fill cap (2) and add oil if necessary.

3. Clean and install fill cap (2).

Hydraulic System

Check the Oil Level

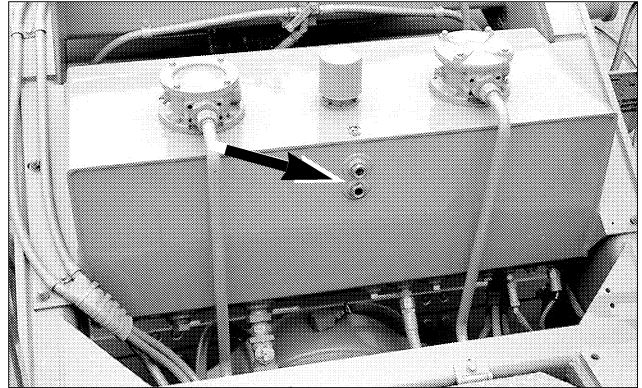

Maintain the oil level between the two sight gauges.

NOTE: Allow for expansion of the hydraulic oil. Do not overfill.

Radiator

Look at the Coolant Level

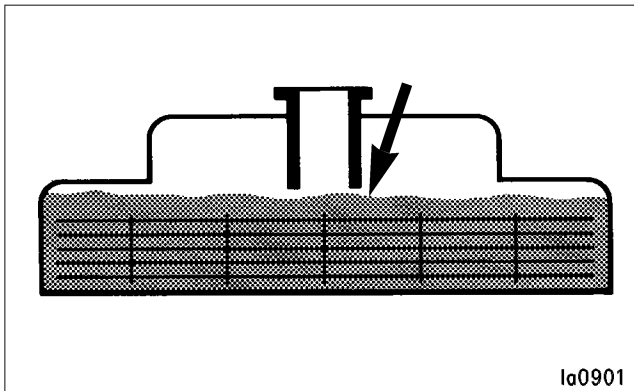

1. Remove the radiator cap slowly to relieve pressure.
2. Maintain the coolant level to within 13 mm (.5 in) of the bottom of the fill pipe. If it is necessary to add coolant daily, check for leaks.
3. Inspect the cap and cap seal for damage, deposits or foreign material. Clean the cap with a clean cloth or replace the cap if it is damaged.
4. Install the cap.
5. Inspect the radiator core for debris and clean if necessary.

Compressed air is preferred, but high pressure water or steam can be used to remove dust, leaves and general debris from a radiator. Clean as required by condition of radiator.

Hydraulic Oil Cooler

Inspect the Core

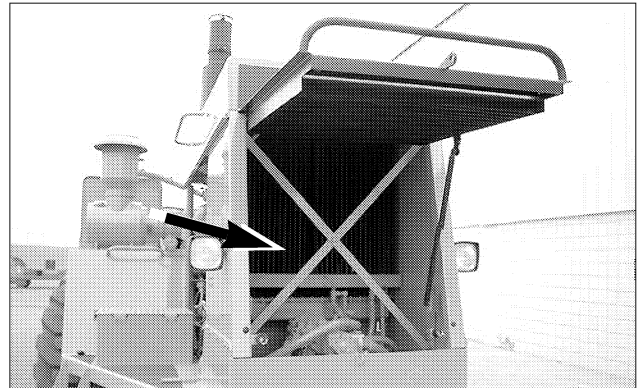

The hydraulic oil cooler is located at the front of the machine.

Compressed air is preferred, but high pressure water or steam can be used to remove dust, leaves and general debris from a core. Clean as required by condition of core.

Refer to "Know Your Cooling System", Form No. SEBD0518, for the complete procedure and instructions.

Bearing Reservoir

Check the Oil Level



Remove the fill plug and visually check the oil level. Add lubricant as necessary.

Tires

Check Pressure/Inspect For Wear

Check the tires daily for proper inflation and abnormal wear. Check the wheel lug nuts for looseness and tighten if necessary.

If the tire pressure is low, check and repair any leaks.

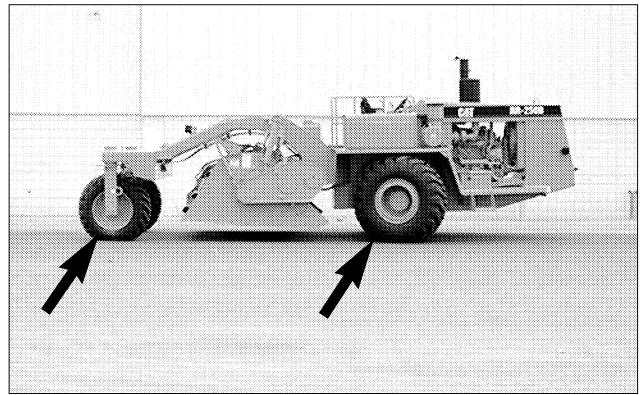

SS-250B: The inflation pressure for each of the front tires is 166 kPa (24 psi). The inflation pressure for each of the rear tires is 124 kPa (18 psi).

RR-250B: The inflation pressure for each of the front tires is 310 kPa (45 psi). The inflation pressure for each of the rear tires is 207 kPa (30 psi).

Rotor Bits and Bit Holders

Check/inspect

WARNING

Inadvertent engagement of the rotor could cause personal injury. Stop the engine and remove the key from the key start switch.

RR-250B:

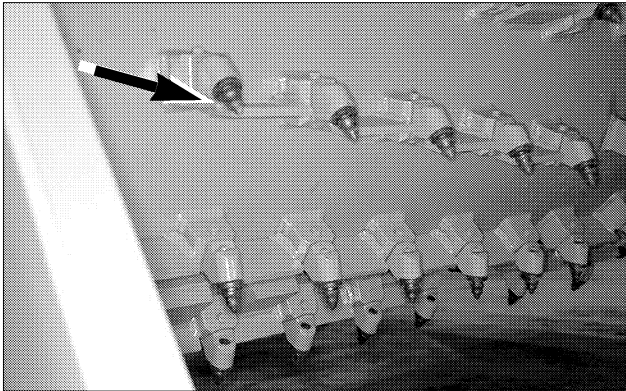

The rotor bits should be checked for excessive wear and replaced anytime the distance from the holders to the tip of the bit (normal wear) or to the end of the supporting metal (carbide tip exposed) is 32 mm (1.25 in) or less.

At the same time the bits are checked, also check the bit holders for breaks or cracks. Replace as necessary.

Replacing A Rotor Bit

When the bits get worn they should be changed as a group so that all of the bits are approximately the same length. If a single bit is longer than those around it, that single bit will wear faster and may be broken off when the bit hits the surface being cut. Keep worn bits on hand to replace broken bits. Always try to replace a broken bit with a bit that is close to the same length as the bits surrounding it.

SS-250B:

Replace broken spade bits, bits that have lost the carbide plates, and bits that show excessive erosion behind the carbides so that short life remains. Replace bits with other bits showing approximately the same wear as the majority of the other bits.

When replacing a full set with new bits, keep worn bits for interim replacements.

To Remove a Bit

1. Clear all personnel from around the machine.
2. Start the engine and raise the hood and rotor.
3. Rotate the rotor until the bit is accessible. Disengage the rotor clutch. Use a lock to lock-out the rotor clutch lever in the disengaged position.
4. Attach the chaincase chains to the frame.
5. Raise the door and install the lock bar. Stop the engine. Remove the key.
6. Insert the tip of a drive pin into the opening of the bit holder. Strike the drive pin with a hammer to drive the bit out.
7. Position the new bit in the holder and drive it into place with a hammer. Be sure the keeper spring is engaged with the holder.

NOTE: The rotor can be rotated by hand when the clutch is disengaged.

To Replace A Damaged Bit Holder

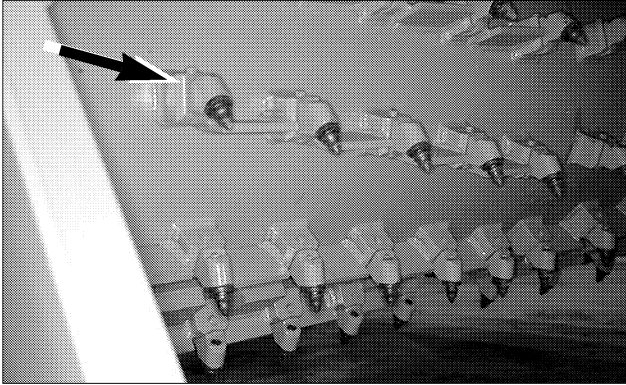

WARNING

Inadvertent engagement of the rotor could cause personal injury. Use a lock to lockout the rotor clutch lever in the disengaged position. Stop the engine and remove the key from the key start switch.

Metal that has been ground or cut with a torch will be hot and could cause serious burns if touched. Do not touch the bit holder or rotor drum until they have cooled.

Welded Holder

1. Use a torch or grinder to cut the bit holder from the drum.
2. Grind the surface of the drum smooth.
3. Position and weld the new bit holder on the rotor drum at the same location and orientation.

Breakaway Holder

1. Remove Bolt.
2. Knock out holder.
3. Install holder and hammer into place.
4. Tighten bolt. Hammer and tighten bolt again.

Seatbelt

Inspect



Inspect the seat belt and mounting hardware for wear, damage and looseness. Repair as necessary.

Walk-Around Inspection

Inspect the Machine

NOTICE

Accumulated grease and oil on a machine is a fire hazard. Remove this debris with steam cleaning or high pressure water, at least every 1000 hours or each time any significant quantity of oil is spilled on a machine.

NOTE: Keep a close watch for leaks. If leaking is observed, find the source and correct the leak. Check the fluid levels more frequently than the recommended periods if leaking is suspected or observed.

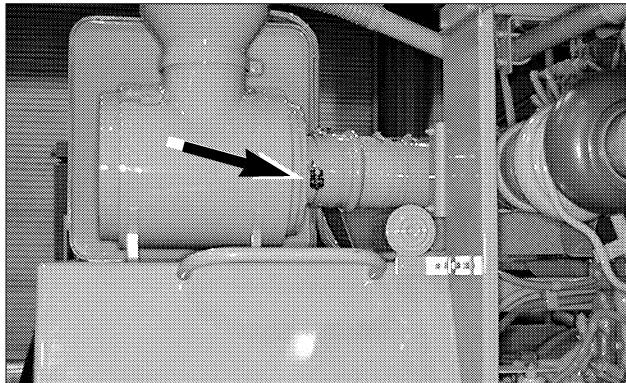

Service the air cleaner when the red strip is visible in the indicator.



Inspect the steps, walkways and handholds for their condition and cleanliness.

Inspect the operator's compartment for cleanliness. Keep it clean.

Inspect the lights (if equipped) for broken bulbs and lenses. Replace if broken.

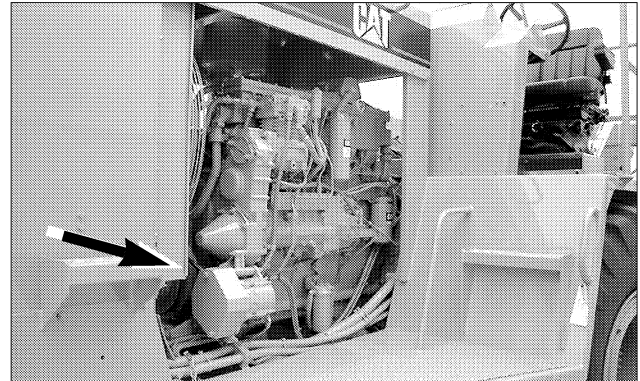

Inspect and remove any trash build up in the engine compartment.

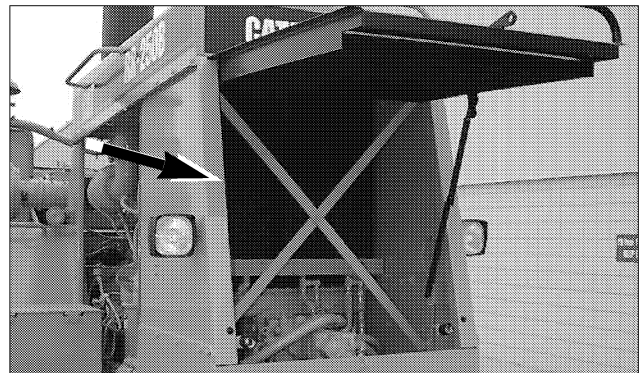

Inspect the cooling system for leaks, faulty hoses and trash build up. Correct any leaks and remove any trash from the radiator.

Inspect all engine attachment belts for worn cracked or frayed edges. Replace if worn, cracked, frayed or broken.

Inspect the hydraulic system for leaks. Inspect the tank, cylinder rod seals, hoses, tubes, plugs, joints and fittings. Correct any leaks.

Inspect all steps and handholds for condition and cleanliness. Check the Rollover Protective Structure (ROPS) for damage and loose bolts.

Be sure the covers and guards are firmly in place. Inspect for damage.

Indicators and Gauges

Test for Proper Function



Look for broken gauge lenses or indicator lights, switches, etc.

Start the engine.

Look for inoperative gauges.

Turn all machine lights on (if equipped). Check for proper operation.

Depress the horn button to test for proper operation.

Stop the engine.

Make any needed repairs before operating.

Back-up Alarm

Test

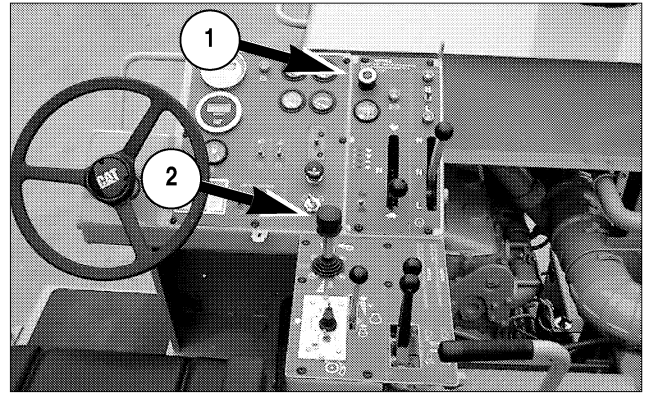

1. Start the engine and engage parking brake (1).

2. Move propel lever (2) just slightly towards reverse. Do not move the lever to full reverse to avoid moving the machine.

3. If the machine starts to move, the brake interlock is faulty.

The alarm should start to sound immediately. It will continue to sound until the travel lever is moved to STOP or forward.

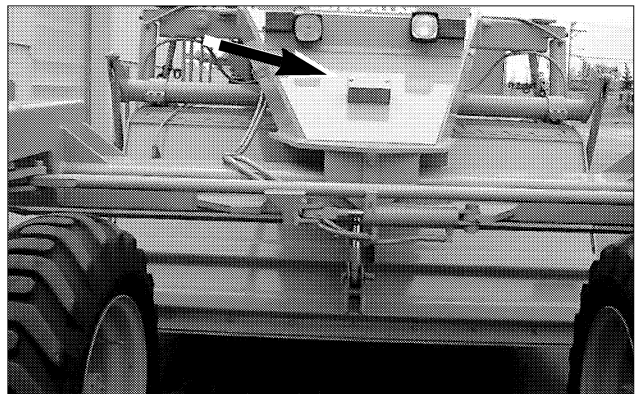

The back-up alarm is located on the rear of the machine.

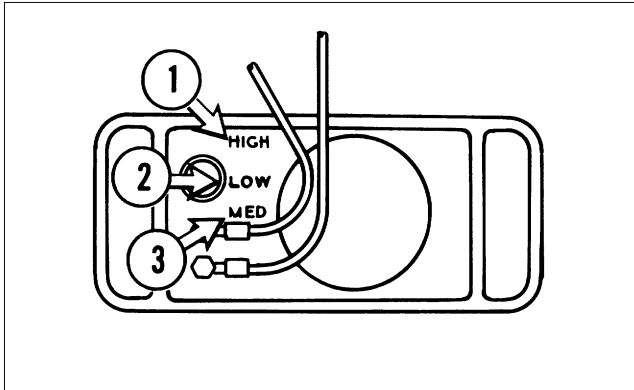

The sound level can be adjusted by moving the adjustment on back of alarm to meet operating requirements. The alarm is set at the highest sound level when shipped from the factory. The setting should remain on high (1), unless the job-site requires a lower level, such as low (2) or medium (3).

4. Move the propel lever to the STOP position.
5. Stop the engine.

Air Tanks

Drain

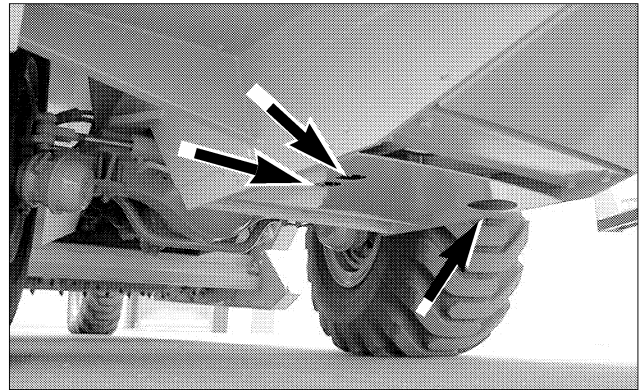

Reach through the access holes and open the drain valves to drain the moisture from the tanks.

Initial 25 Service Hours

You must read and understand the warnings and instructions contained in the Safety Section of this manual, before performing any operation or maintenance procedures.

Propel System Suction Filter

Change

See, "Every 250 Service Hours".

Auxiliary Return Filter

Change

See, "Every 250 Service Hours".

Initial 50 Service Hours

You must read and understand the warnings and instructions contained in the Safety Section of this manual, before performing any operation or maintenance procedures.

Rotor Clutch Lever

Check Force Required to Engage Clutch

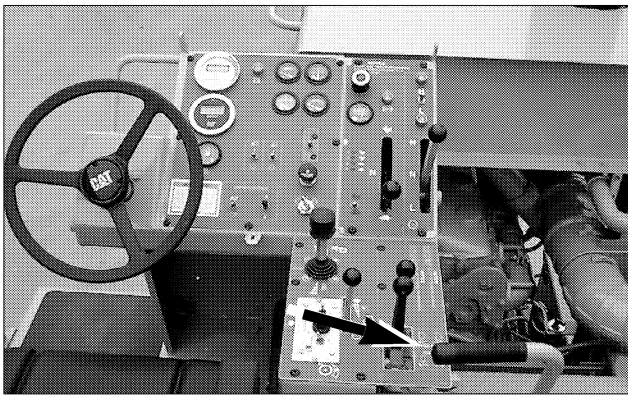

Check the force (at the hand grip lever) required to engage the clutch. If the force required is not 180-200 N (40-45 lb), refer to "Rotor Clutch Plate Pressure Adjustment" in the service manual, for the adjustment procedure.

Every 50 Service Hours or Weekly

You must read and understand the warnings and instructions contained in the Safety Section of this manual, before performing any operation or maintenance procedures.

Propel Axle & Planetary Ends

Check Oil Level

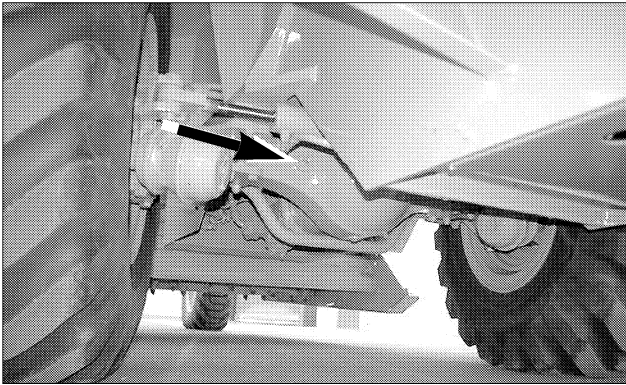

1. Remove the check/fill plug.
2. If lubricant does not flow from the plug port, add lubricant until the check/fill plug level is reached.
3. Install the check/fill plug.

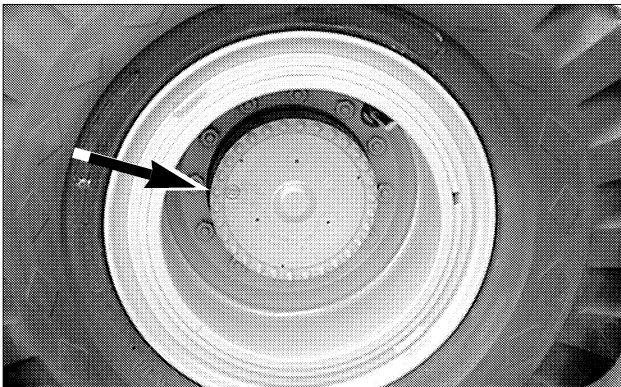

4. With the machine on a level surface, line up the oil level line so that it is parallel with the ground.
5. Remove the check/ fill plug and add lubricant if necessary.

Propel Axle Gearbox

Check Oil Level

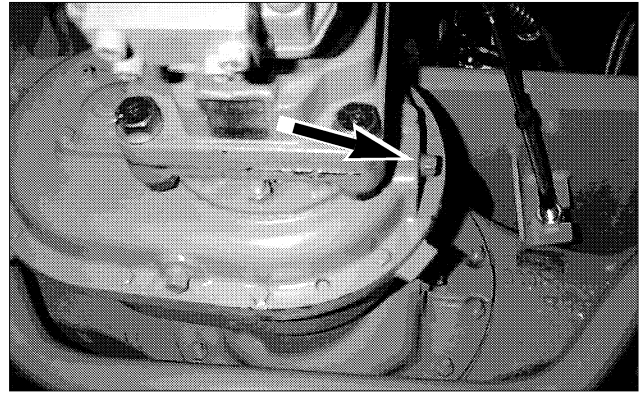

1. Remove the check/fill plug.
2. If lubricant does not flow from the plug port, add lubricant until the check/fill plug level is reached.
3. Install the check/fill plug.

Rotor Transmission Drive Oil

Check the Oil Level

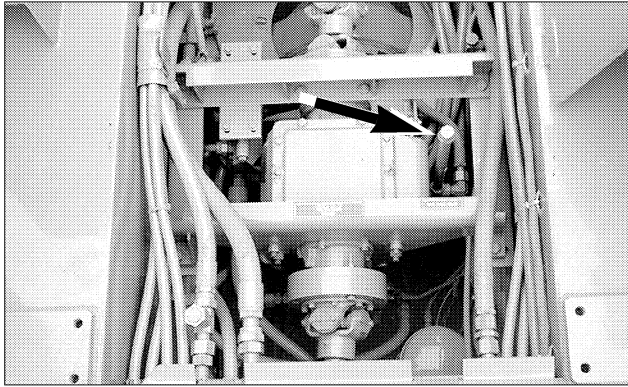

Remove the fill cap and check the oil level on the dipstick. Maintain the level to the FULL mark on the dipstick. Add lubricant as necessary.

Rotor Chaincase

Check the Oil Level

1. Start the engine and lower the rotor to the ground.

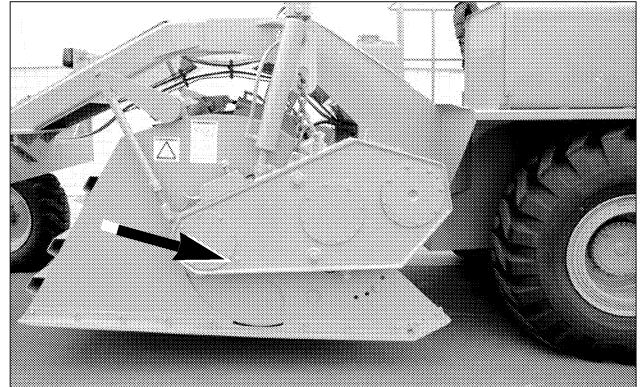

2. Remove the check plug from the rotor chaincase.
3. If oil does not flow from the plug port, fill the chaincase to the check plug level.
4. Clean and install the check plug.
5. Repeat Steps 2 through 4 on the other chaincase.

Rotor Drive Shafts

Lubricate

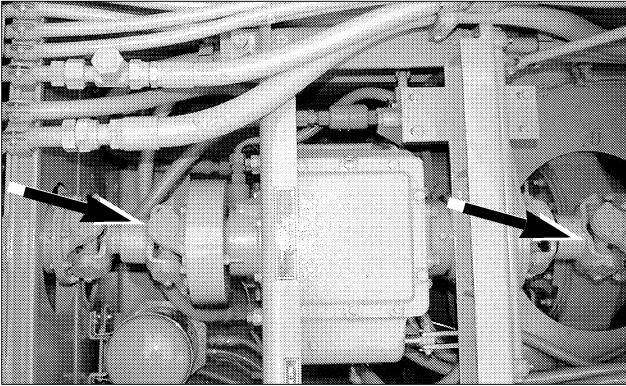

Lubricate six fittings.

Hood Cylinder

Lubricate



Lubricate two fittings.

Hood Torque Tube

Lubricate

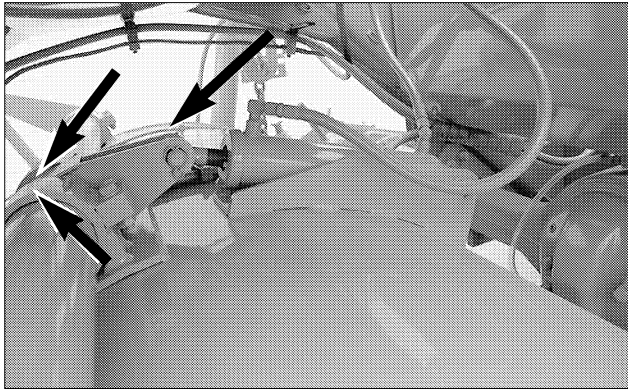

Lubricate three fittings.

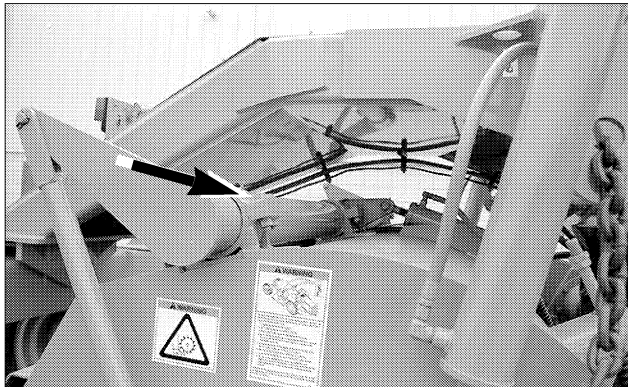

Lubricate one fitting at each end of the torque tube.

Chaincase Shaft Bearings

Lubricate

NOTICE

Do not use more lubrication than specified on the chaincase shaft bearings. Too much grease will cause a build up of sludge in the chaincase.

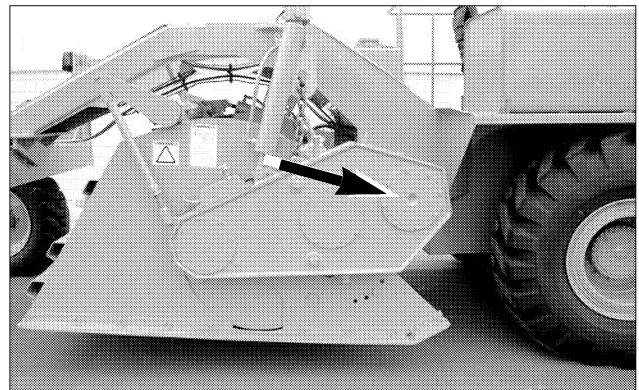

Lubricate one fitting at each side of the machine. Use one to three pumps from a manual grease gun. If it appears a sludge is starting to build up in the chaincase, increase the service interval from 10 to 15 service hours.

Chaincase Lift Cylinders

Lubricate

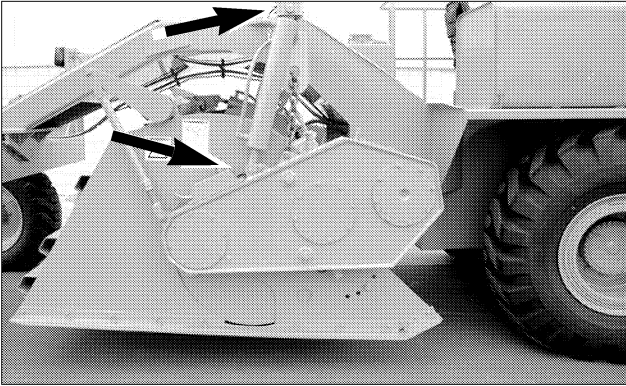

Lubricate one fitting at each end of both cylinders.

Rear Leg Pivot Pins

Lubricate

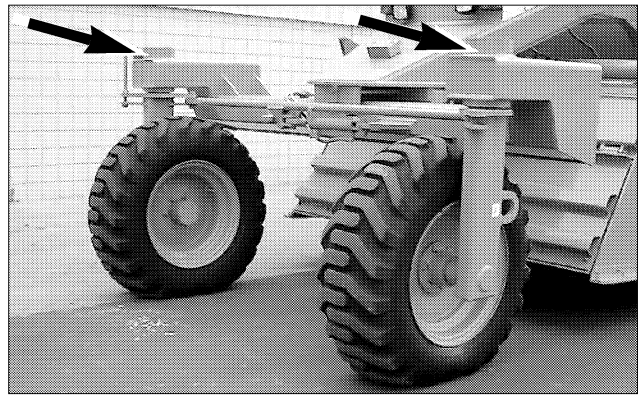

Lubricate one fitting on each side.

Rear Steer Cylinder

Lubricate

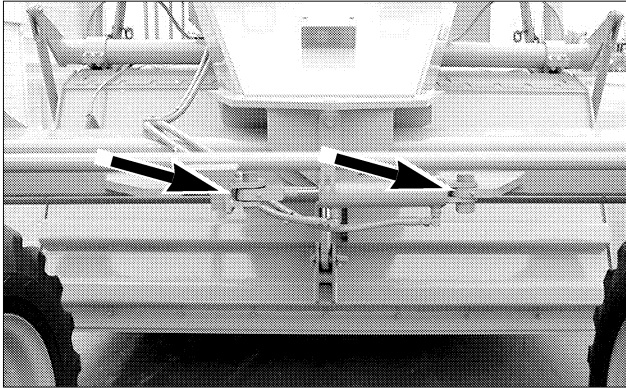

Lubricate two fittings.

Chaincase Supports

Lubricate

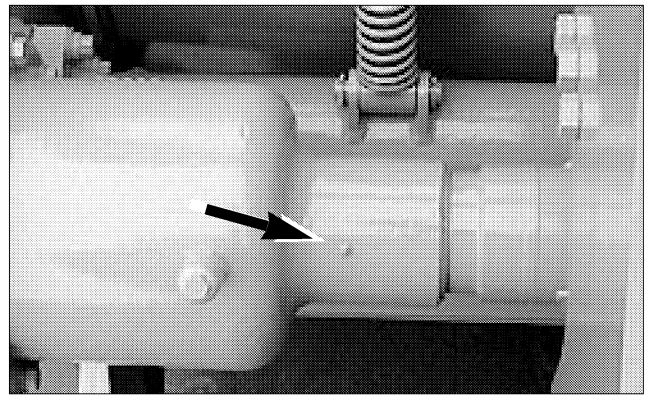

Lubricate two fittings. (One fitting at each end).

Engine Air System

Check Intake and Exhaust Systems



NOTICE

Intake air leaks allow dirt entry into the engine which greatly accelerates engine wear.

Check all clamps, bolts and ducting on the engine intake and exhaust systems. Make repairs as required to prevent leaks and to ensure air cleaners and mufflers are securely mounted.

Fuel Tank

Drain Water and Sediment

WARNING

Diesel fuel is volatile and could ignite or explode, causing serious burns and injuries from flying objects. Never smoke or have an open flame while working on the fuel system.

NOTE: Dispose of drained material according to local regulations.

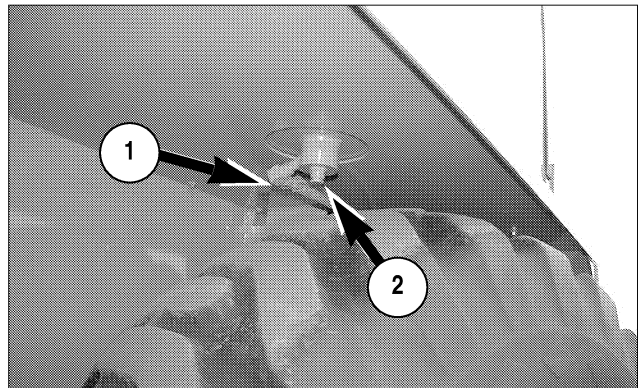

Allow the machine to stand at least fifteen minutes after adding fuel or after operation to let water and sediment settle.

1. Close valve (1) below the fuel tank on the right side of the machine.
2. Remove plug (2) and allow water and sediment to drain.
3. Install plug (2).
4. Open valve (1).

Axle Tie Rod and Steer Cylinder

Lubricate

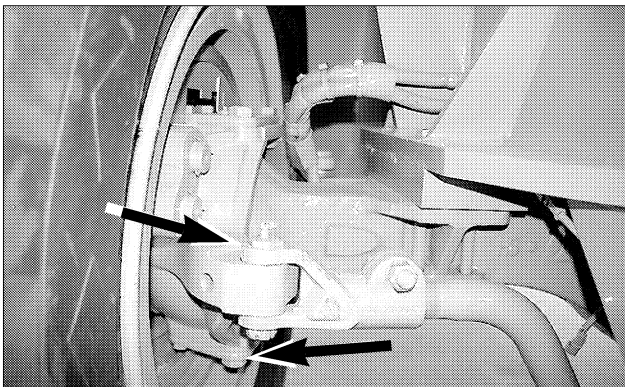
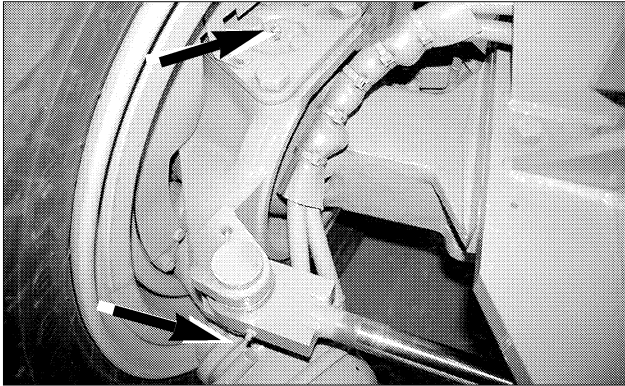

Lubricate four fittings at each side.

Shear Disc Bushing

Lubricate

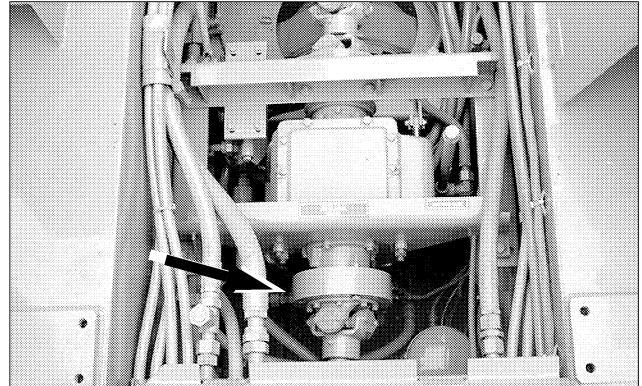

Lubricate one fitting.

Depth Gauge Pivot

Lubricate

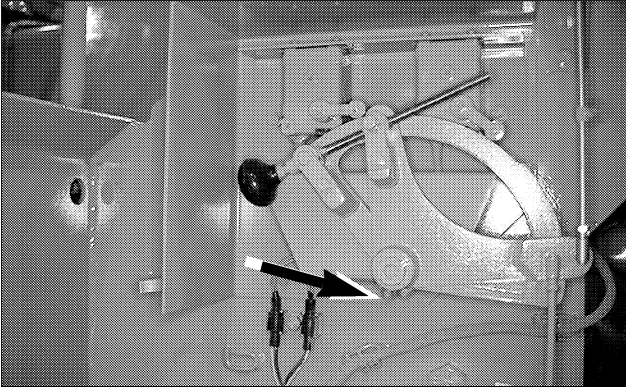

Lubricate one fitting.

Rotor Axle

Check Level

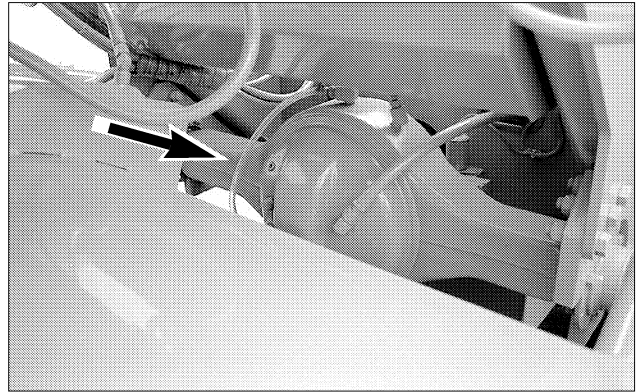

Maintain the oil level in the tube to the centerline of the axle.

Every 125 Service Hours or 2 weeks

You must read and understand the warnings and instructions contained in the Safety Section of this manual, before performing any operation or maintenance procedures.

Pump Drive Shaft

Lubricate

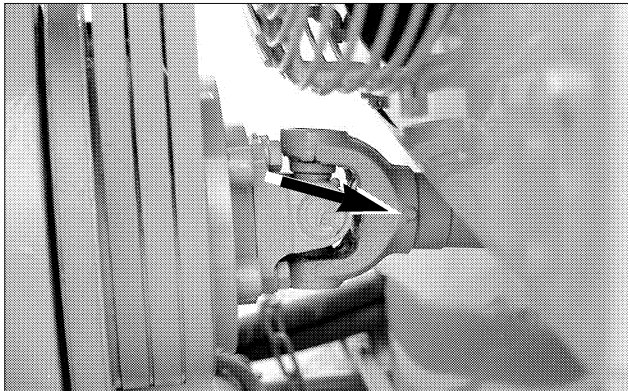

Lubricate three fittings.

Rotor Clutch Collar, Bearings & Release Lever

Lubricate

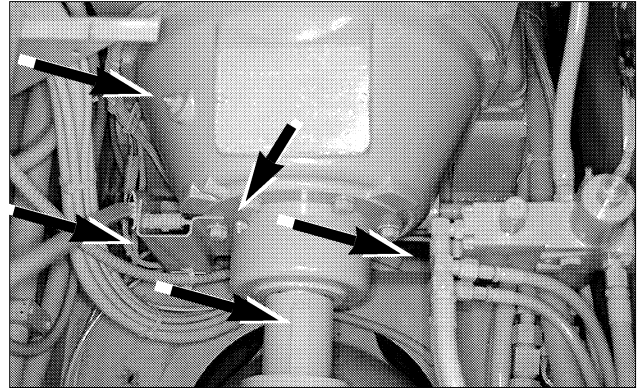

Lubricate five fittings.

92
Maintenance Section
Every 125 Service Hours or 2 Weeks

Rotor Torque Limiter (If Equipped)

Check wear indicator

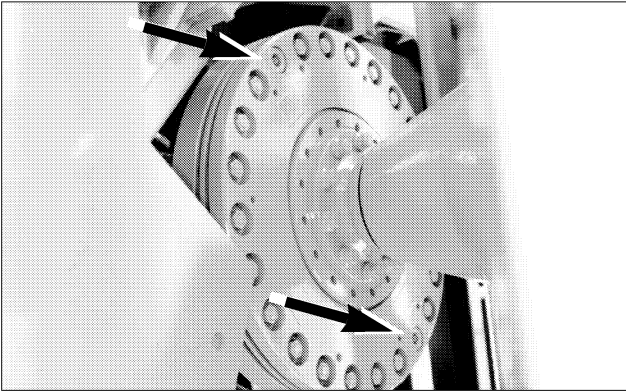

When the indicators are flush with the surface of the clutch, the clutch must be rebuilt.

Every 250 Service Hours or Monthly

You must read and understand the warnings and instructions contained in the Safety Section of this manual, before performing any operation or maintenance procedures.

Propel System Suction Filter

Change

WARNING

Hot hydraulic oil can cause burns. Allow the machine to stand idle until the tank is cool enough to touch with your hands.

1. Remove the hydraulic tank cap to relieve pressure in the tank. Install the hydraulic tank cap.

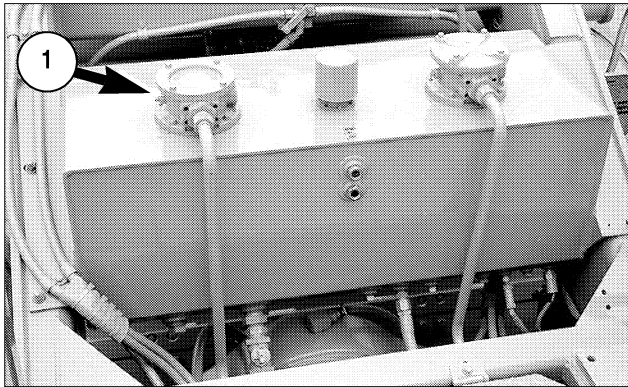

2. Remove cap assembly (1).
3. Remove the spring, filter element and center rod from the filter enclosure assembly.
4. Install a new filter element. Install the center rod and spring.
5. Install the cap assembly.

Auxiliary Return Filter

Change

WARNING

Hot hydraulic oil can cause burns. Allow the machine to stand idle until the tank is cool enough to touch with your hands.

1. Remove the hydraulic tank cap to relieve pressure in the tank. Install the hydraulic tank cap.

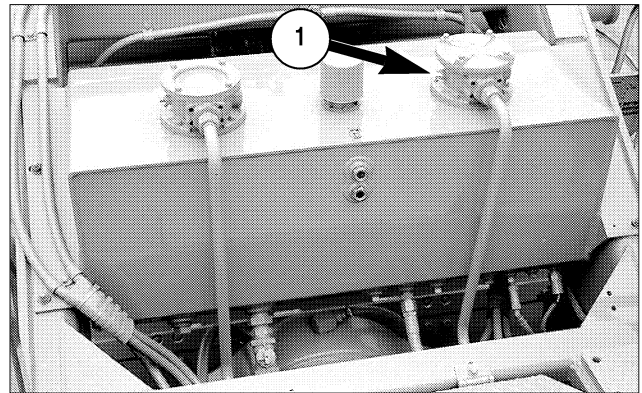

2. Remove cap assembly (1).
3. Remove the spring and filter element from the filter enclosure assembly.
4. Install a new filter element. Install the spring.
5. Install the cap assembly.

Engine Oil and Filters

Change the Oil and Filters

WARNING

Hot oil or components can cause burns if they contact skin. Use caution when draining oil or changing filters.

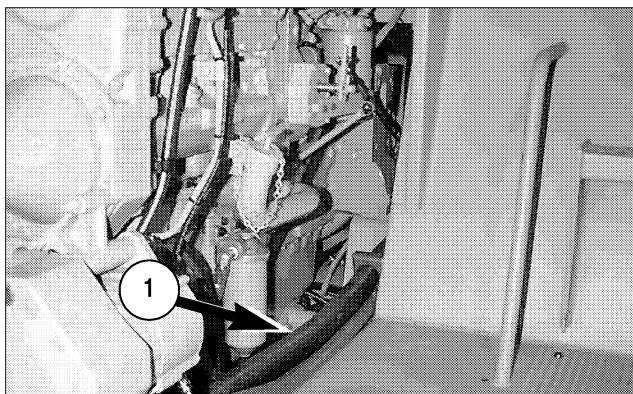

1. Remove crankcase drain valve (1). Allow the oil to drain into a suitable container.

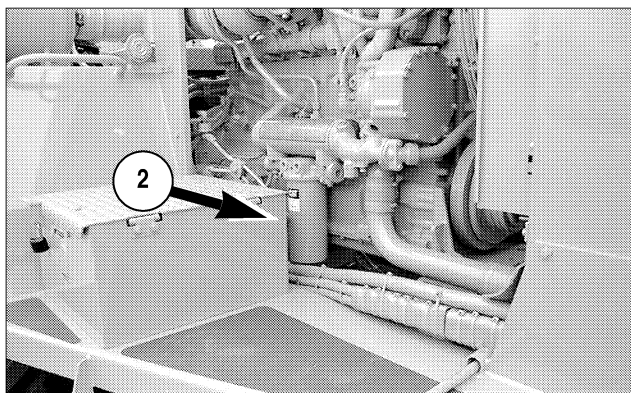

2. Remove and discard filter element (2) with a strap-type wrench. Refer to Filter Inspection in the When Required section.

3. Clean the filter housing base. Make sure all of the old filter gasket is removed.

4. Apply a light coat of engine oil to the gasket of the new filter.

5. Install the new 1R-0716 filter by hand. When the gasket contacts the filter base, tighten the filter three-quarters of a turn more.

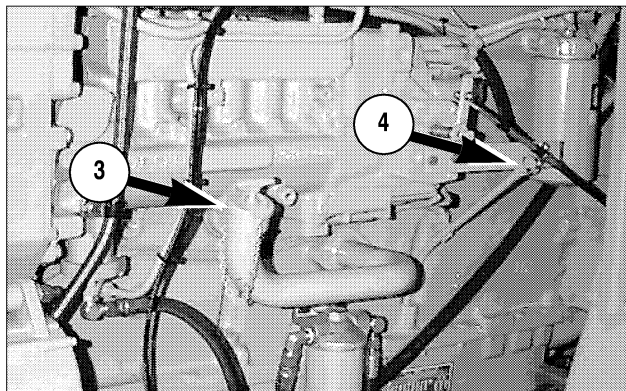

6. Remove oil fill plug (3). Fill the crankcase with new oil. The capacity is 34 liters (9 U.S. gallons). Clean and install oil fill plug (3).

7. Start the engine and allow the oil to warm. Check for leaks. With the engine running, maintain the oil level between the "L" and the "F" marks on the LOW IDLE side of dipstick (4).

8. Stop the engine.

9. Wait to allow the oil to drain back into the crankcase. Check the oil level. With the engine stopped, maintain the oil level between the "L" and the "F" marks on the ENGINE STOPPED side of dipstick (4).

Engine Valve Lash

Adjust

Adjust valve lash on new and reconditioned engines at first oil change and then every 2000 service hours. See, "Every 2000 Service Hours or 1 Year".

Cooling System

Replace Supplemental Coolant Additive Element

Refer to the Cooling System Specifications section of this manual for all cooling system requirements.

Use the 8T-5296 Test Kit to check for concentration.

NOTICE

Excessive additive (greater than the recommended 6% initial fill) together with concentrations of antifreeze greater than 60% cause deposits to form and can result in radiator tube blockage and overheating.

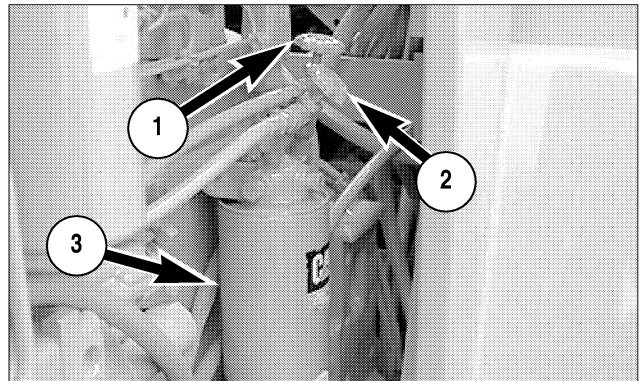

1. Close coolant inlet valve (1) and outlet valve (2). Remove and discard element (3).
2. Clean the element mounting base. Make sure all of the old gasket is removed.
3. Replace with a new Caterpillar maintenance element.
4. Coat the gasket of the new element with a thin film of engine oil.
5. Install and turn the element until the seal contacts the base, then tighten three-quarters of a turn more.
6. Open inlet valve (1) and outlet valve (2).
7. Remove the fill cap.
8. Start the engine and check for leaks. Allow the coolant level to stabilize.
9. Add premixed coolant if necessary to bring the coolant to within 13 mm (.5 in) below the bottom of the fill pipe.

Belts

Inspect Fan, Alternator and Transmission Lube Pump Belts

For maximum engine performance and utilization of your engine, inspect the belts for wear and cracking. Check and adjust the belt tension to minimize belt slippage which will decrease belt life and cause poor performance of alternator and any driven equipment.

1. Inspect the condition of the belts.
2. Inspect the tension of the alternator belt.

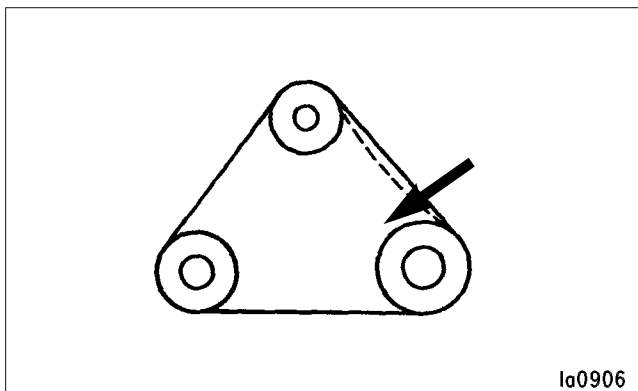

To check the alternator and fan belt tension, apply a 110 N (25 lb) force midway between the pulleys. Correctly adjusted belts will deflect 10 to 15 mm (.4 to .6 in).

If new belt(s) are installed, check belt adjustment again, after 30 minutes of operation. For multiple belt drive applications, always replace belts in matched sets.

If only one belt of a matched set is replaced, it will carry more of a load than the belts not replaced since the older belts are stretched. The additional load on the new belt could cause it to break.

Alternator Belt Adjustment

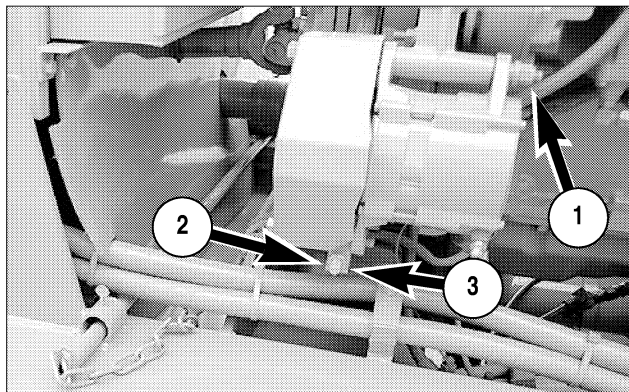

1. Loosen bolt (1). Loosen jam nut (2).
2. Turn adjusting nut (3) to obtain the proper adjustment.
3. Tighten jam nut (2) and bolt (1).

Fan Belt Adjustment

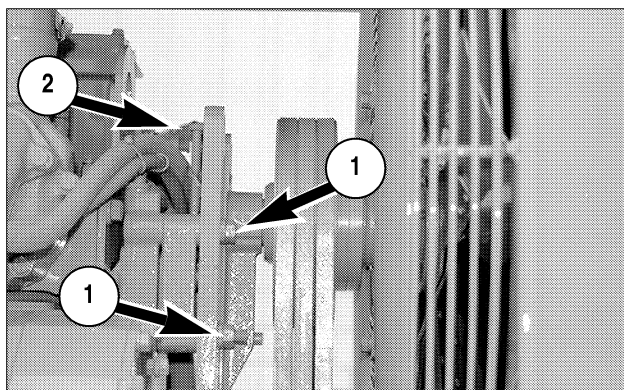

1. Loosen bolts and nuts (1). (Four total).
2. Turn adjusting bolt (2) to adjust the tension on the belts.
3. When the correct belt tension is obtained, tighten the mounting bolts. Recheck the belt adjustment.

Transmission Lube Pump Belt Adjustment

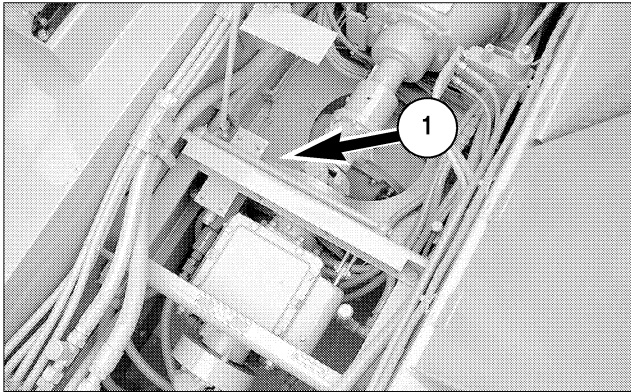

1. Loosen bolt (1) under the pump.
2. Use a prybar to hold tension on the lube pump.
3. When the correct belt tension is obtained, tighten the mounting bolt.
4. Recheck the belt adjustment.

Fan Bearing

Lubricate

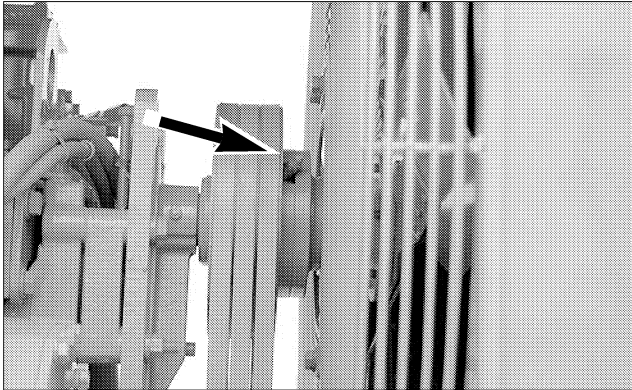

Lubricate one fitting.

Propel Axle U-Joints

Lubricate

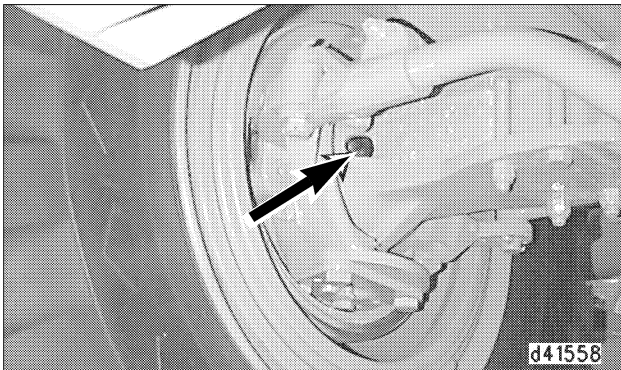

Lubricate one fitting at each side of the axle.

NOTE: Disregard this maintenance item if there are no fittings installed.

Batteries

Check Electrolyte Level

Tighten the battery retainers every 1000 hours on all batteries.

Check the following at least every 1000 hours, and more often as conditions require:

BATTERY ELECTROLYTE CHART	
Battery	Interval
Conventional	100 Hours
Low Maintenance	250 Hours
Maintenance Free	None Required

- Clean the top of the batteries with a clean cloth.
- Keep the terminals clean and coated with petroleum jelly.

At the proper charging rate, in a moderate climate, a battery should not require more than 30 cc (1 ounce) of water per cell per week.

Check the cells weekly in extreme temperatures, cell water usage could be higher.

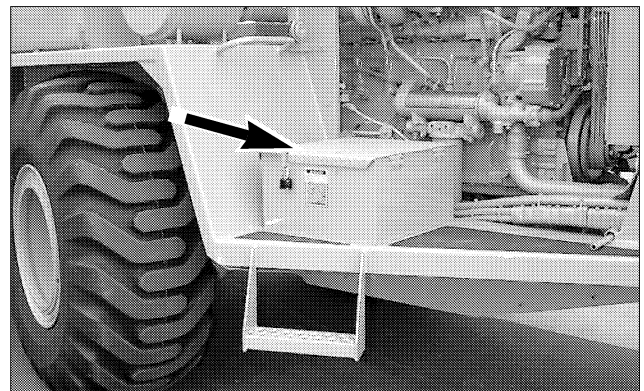

1. Open the battery access cover located on the right, front of the machine.

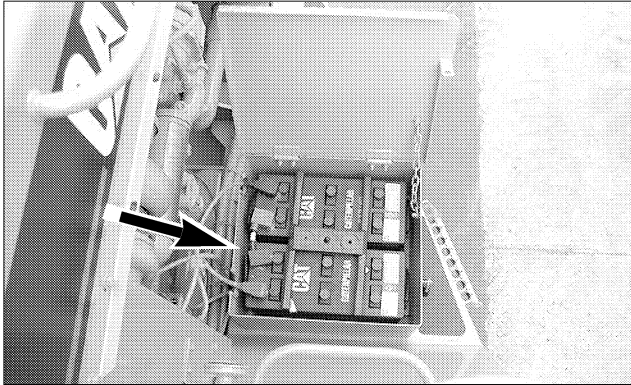

2. Clean the battery surface with a clean cloth. Keep the terminals clean and coated with petroleum jelly. Install the post cover after coating.

3. Inspect the electrolyte level in each battery cell (except maintenance free batteries). Maintain the level to the bottom of the fill openings with distilled water. If distilled water is not available, use clean drinking water.

4. Close the access cover.

Replacement of Battery, Battery Cable or Disconnect Switch

1. Turn the engine start switch to OFF. Turn all switches to the OFF position.

2. Turn the battery disconnect switch key to OFF and remove the key.

3. Disconnect the negative (-) battery cable, at the battery disconnect switch, that is connected to the machine frame.

NOTE: Do not allow the disconnected battery cable to contact the disconnect switch.

4. Disconnect the negative (-) battery cable at the battery.

5. Make necessary repairs or battery replacement.

6. Connect the negative (-) battery cable at the battery.

7. Connect the battery cable at the battery disconnect switch.

8. Install the key and turn the battery disconnect switch to ON.

Every 500 Service Hours or 3 Months

You must read and understand the warnings and instructions contained in the Safety Section of this manual, before performing any operation or maintenance procedures.

Fuel System

Clean and Change Filters

NOTICE

Do not fill fuel filters with fuel before installing them. Contaminated fuel will cause accelerated wear to fuel system parts.

Wash the Primary Filter Element

1. Close the fuel shutoff valve located under the fuel tank.

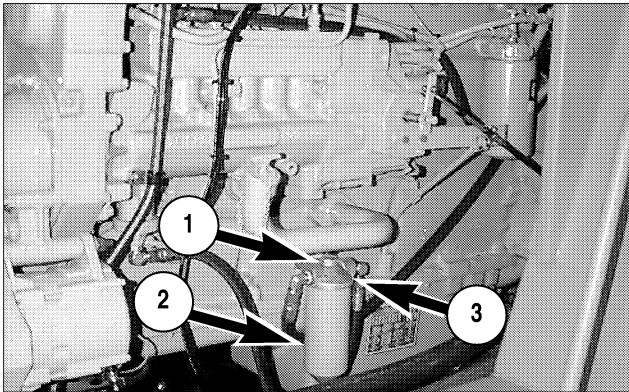

2. Loosen filter housing retaining nut (1).
3. Remove case (2) and remove the element from the case.
4. Wash the element and case in clean, nonflammable solvent.
5. Dry the element using pressure air - 205 kPa (30 psi) maximum.
6. Clean filter case base (3).
7. Inspect the seal. Replace it if it is damaged.
8. Insert the clean element into case (2).
9. Install the element and case (2) onto base (3).

10. Tighten filter housing retaining nut (1) to a torque of $24 \pm 4 \text{ N}\cdot\text{m}$ ($18 \pm 3 \text{ lb ft}$).

Change Secondary Fuel Filters

1. Remove and discard the filter element.

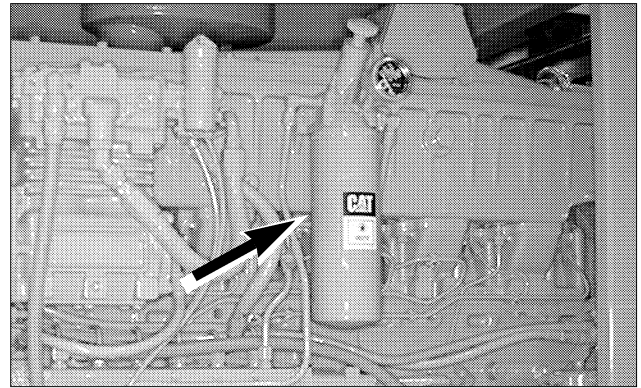

2. Clean the filter mounting base. Be sure all of the old seal is removed.
3. Coat the seal of a new filter with clean diesel fuel.
4. Install the new filter by hand. When the seal contacts the base, tighten 3/4 turn more.

There are rotation-index marks 90 ° apart on the filter. Use them as a guide for proper tightening.

5. Open the fuel shutoff valve located under the fuel tank.
6. Prime the fuel system. Refer to the next topic.

Priming the Fuel System

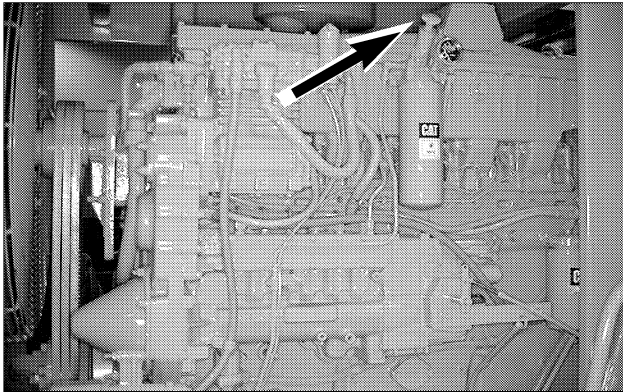

1. Unlock and pull out the priming pump plunger.
2. Operate the pump to fill the new filters with fuel. Continue pumping until resistance is felt, indicating the filters are full of fuel.
3. Push the priming pump plunger down and lock it.
4. Start the engine and look for leaks around the filters.

If the engine fails to start or continues to misfire or smoke, further purging is necessary. With the engine running, or with the use of the priming pump, loosen the fuel line nuts, one at a time, several times in succession and allow fuel to flow until free of air bubbles. Use two wrenches to avoid breaking fuel lines. Tighten the fuel line nuts.

Fuel Tank Cap And Fill Screen

Clean

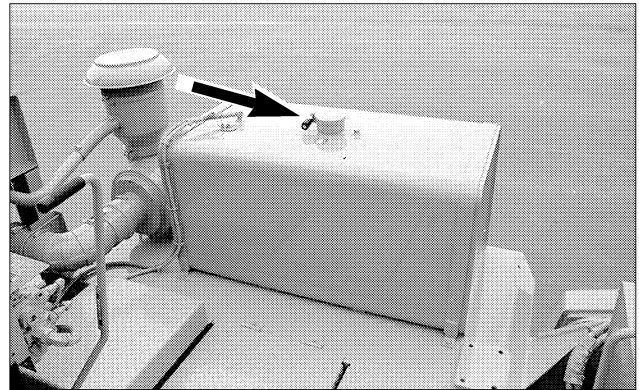

Clean the fuel tank cap and fill screen.

Hydraulic System

Change oil and filters

When changing the hydraulic oil, cleanliness must be kept in mind at all times. Perform the work in a clean area. Use clean tools, keep your hands clean, and clean the outside of the hydraulic tank before putting the machine back in service.

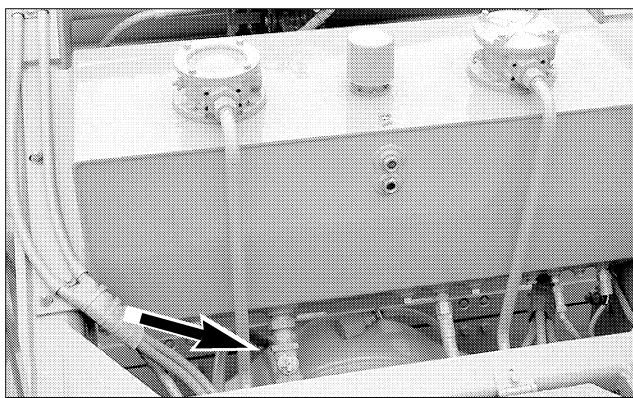

WARNING

At operating temperature, the hydraulic oil can cause serious burns. Let the machine stand idle until the oil has cooled and you are able to touch the hydraulic tank with your hand.

1. Remove the drain plug from the valve at the bottom of the tank and open the valve. Drain the oil into a suitable container. Allow the oil to drain completely.
2. Pour a small amount of clean hydraulic oil in the tank to clean out the bottom of the tank.
3. Install the drain plug and close the valve.
4. Fill the hydraulic tank with clean hydraulic oil that meets the requirements given in "Lubricant Specifications".
5. Change the propel system suction and auxiliary return filter elements. See, "Every 250 Service Hours".

Propel Axle/Propel Axle Gearbox

Change oil

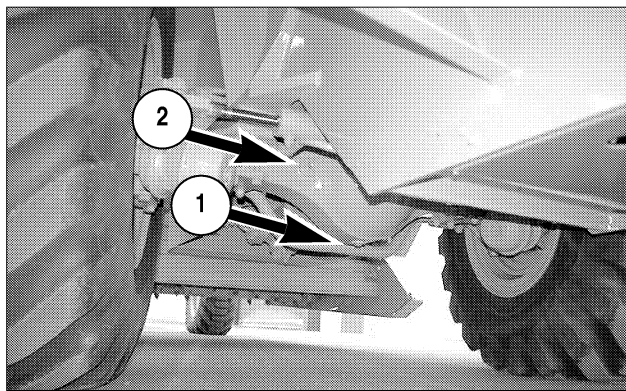
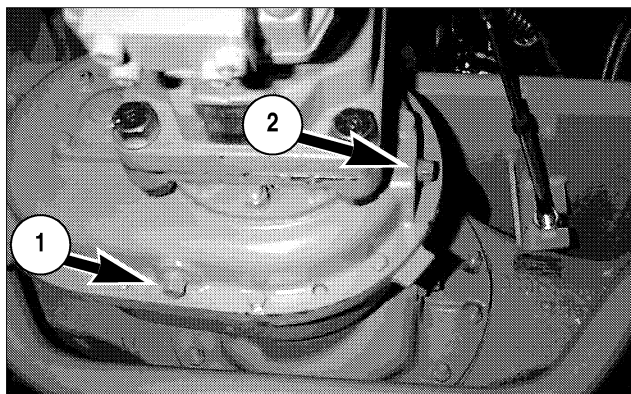

WARNING

Hot oil or components can cause burns if they contact skin. Use caution when draining oil. Allow machine to stand idle until the transmission case is cool enough to touch with your hand.

1. Remove drain plug (1), check/fill plug (2) and allow the oil to drain.
2. Install drain plug (1). Fill the gearbox with lubricant meeting the requirements in "Lubricant Specifications".
3. Install check/fill plug (2).

Rotor Chaincase

Change Oil

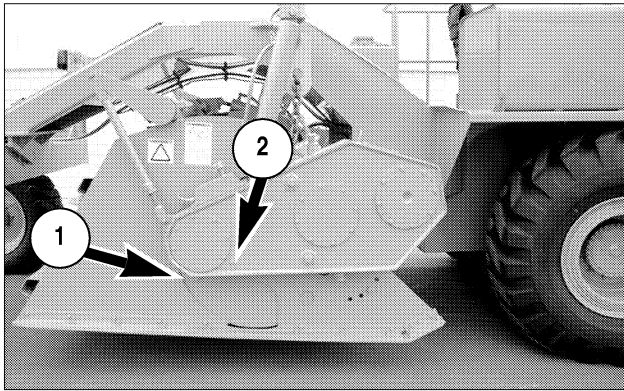

1. Lower the rotor to rest on the ground.
2. Remove drain plug (1).
3. Install the drain plug. Remove fill/check plug (2) and fill with oil.
4. Install fill/check plug (2).

Propel Axle Planetary Ends

Change oil

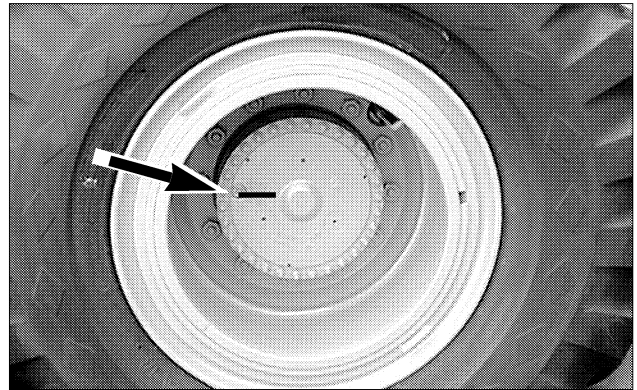

1. Position the machine so that the drain plug is at the lowest level for complete draining of oil. Remove the drain plug
2. When the oil is completely drained, install the drain plug.
3. With the machine on a level surface, line up the oil level line so that it is parallel with the ground.
4. Remove the check/ fill plug and add lubricant. The capacity is 3.3 liters (.9 U.S. gallons).
5. Repeat Steps 1 through 4 for the other planetary end.

Rotor Axle

Change Oil

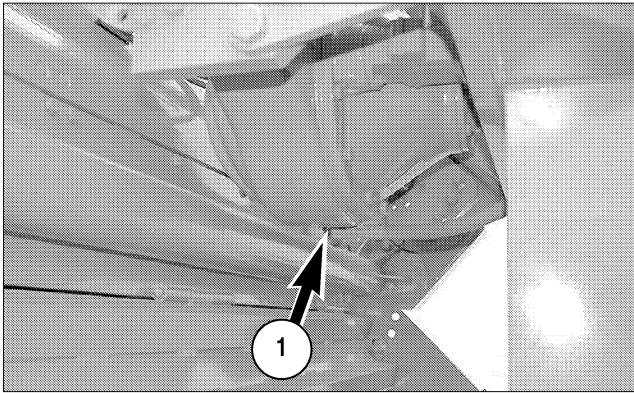

1. Remove drain plug (1) and allow oil to drain into a suitable container.

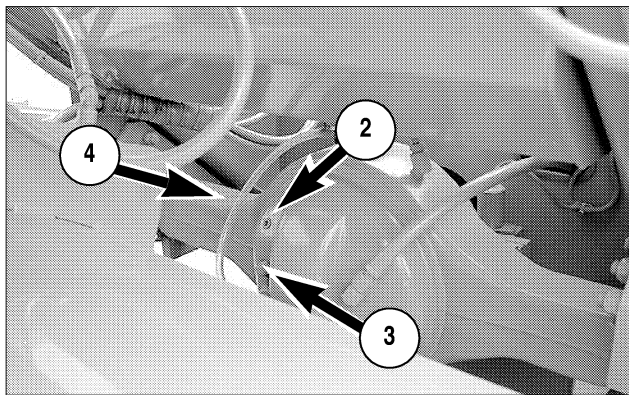

2. Install drain plug (1). Remove fill plug (2) and check plug (3).

3. Fill the axle with oil through the fill hole until oil just starts to come out the check hole.

4. The oil level should be visible in oil level tube (4).

5. Install the fill and check plugs.

Rotor Transmission

Change Oil

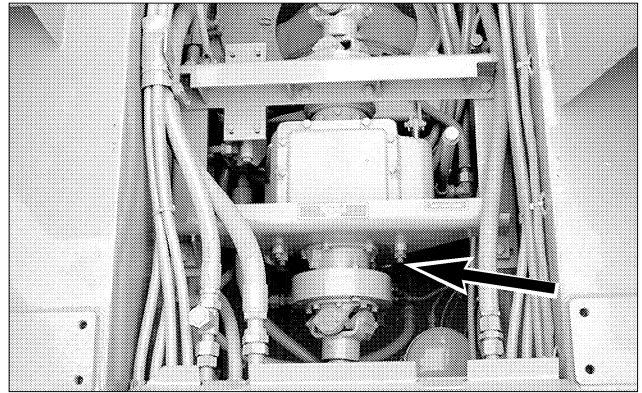

1. Remove drain elbow.

2. Drain Oil.

3. Reconnect drain elbow and refill.

Every 1000 Service Hours or 6 Months

You must read and understand the warnings and instructions contained in the Safety Section of this manual, before performing any operation or maintenance procedures.

Rotor Transmission Shift Linkage

Lubricate

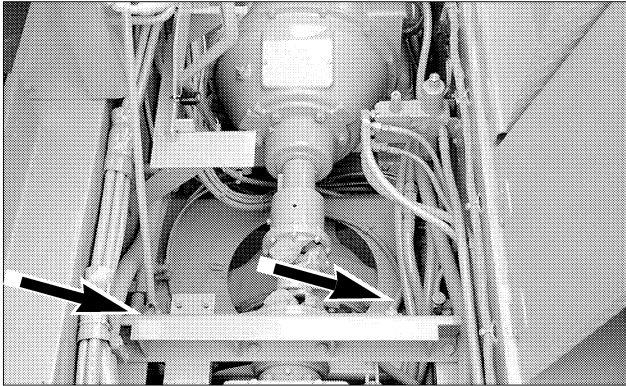

Lubricate two fittings.

Apply SAE 30W oil to the pivot points of the shift linkage.

Rear Wheel Hub Bearings

Lubricate

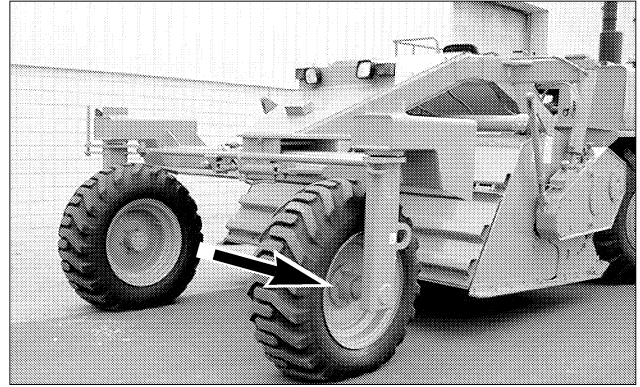

Lubricate two fittings.

Propel Transmission Linkage

Lubricate

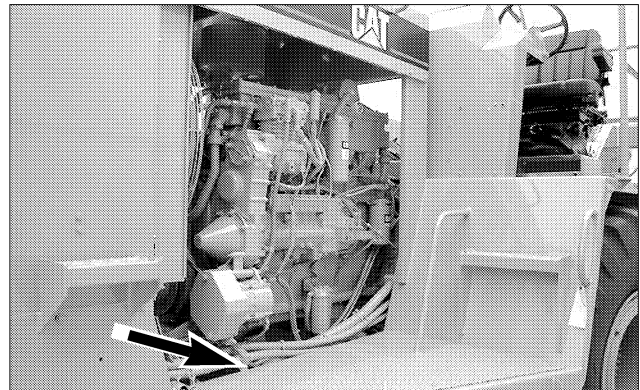

Lubricate two fittings.

106
Maintenance Section
Every 1000 Service Hours or 6 Months

Rollover Protective Structure (ROPS)

Inspect

Inspect the rollover protective structure for cracks, broken welds, loose bolts, excessive wear and damage. Repair as necessary.

Every 2000 Service Hours or 1 Year

You must read and understand the warnings and instructions contained in the Safety Section of this manual, before performing any operation or maintenance procedures.

Engine Valve Lash

Adjust

! WARNING

To prevent possible injury, do not use the starter motor to turn the flywheel.

Hot engine components can cause burns. Allow additional time for the engine to cool before measuring valve clearance.

NOTICE

Measure the valve lash with the engine stopped. To obtain an accurate measurement, allow at least 20 minutes for the valves to cool to engine cylinder head and block temperature.

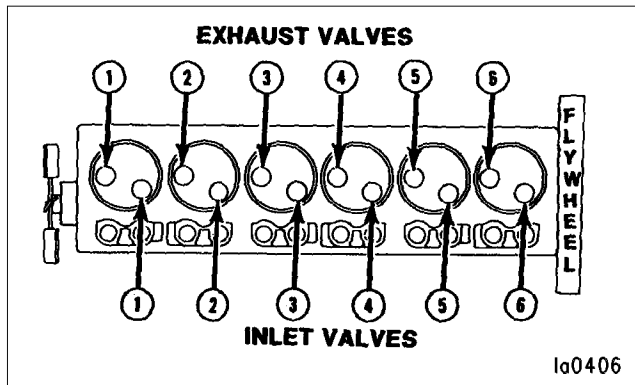

Adjust the valve clearance to within $\pm .08$ mm (.003 in) of the valve clearance setting given in the chart.

Refer to the Service Manual or your Caterpillar dealer for the complete valve adjustment procedure.

NOTE: After setting the valve clearances and before

VALVE CLEARANCE SETTING	
Intake	.38 mm (.015 in)
Exhaust	.76 mm (.030 in)

installing the valve covers, check the valve rotators. Refer to the following topic.

Engine Valve Rotators

Check

! WARNING

When inspecting the valve rotators, protective glasses or face shield and protective clothing must be worn, to prevent being burned by hot oil spray.

1. Start the engine and run at low idle.

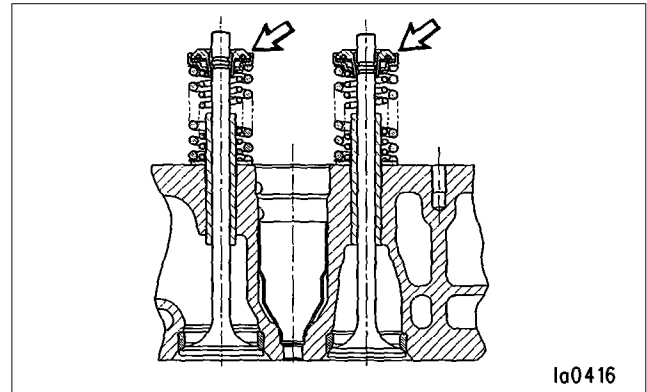

2. Watch the top surface on each valve rotator. Each valve rotator should turn slightly each time the valve closes.

If a valve fails to rotate, contact your Caterpillar dealer.

Every 3000 Service Hours or 2 Years

You must read and understand the warnings and instructions contained in the Safety Section of this manual, before performing any operation or maintenance procedures.

Cooling System Coolant

Change Coolant/Clean System

WARNING

At operating temperature, engine coolant is hot and under pressure.

Steam can cause personal injury.

Check coolant level only when engine is stopped and radiator is cool enough to touch with your hand.

Remove filler cap slowly to relieve pressure.

Cooling system conditioner contains alkali. Avoid contact with skin and eyes to prevent personal injury.

NOTICE

Do not change the coolant until you read and understand the material in the "Cooling System Specifications" section.

All water is corrosive at engine operating temperature. Use either Caterpillar Cooling System Conditioner Liquid or the coolant conditioner element to treat either plain water or ethylene glycol antifreeze solution. Never use both liquid cooling system conditioner and the coolant conditioner element at the same time.

Do not use Caterpillar Cooling System Conditioner or coolant conditioner elements with Dowtherm 209 Full Fill Coolant.

Drain the coolant earlier whenever the coolant is dirty or foaming is observed.

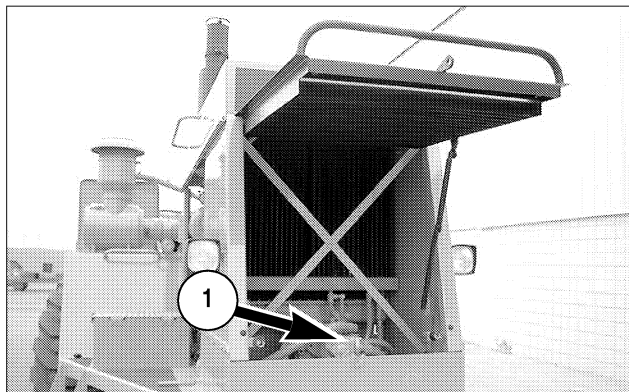

1. Remove the radiator cap slowly to relieve pressure.
 2. Open drain valve (1) and allow the coolant to drain.
 3. Close drain valve (1). Fill the system with clean water and a 6 to 10% concentration of cooling system cleaner.
 4. Start and run the engine for 90 minutes. Stop the engine and drain the cleaning solution.
 5. Flush the system with water, with the engine stopped, until the draining water is clear.
 6. Close drain valve (1).
 7. Add the coolant solution. See "Cooling System Specifications and Lubricant Viscosities and Refill Capacities".
- NOTE: Do not add supplemental coolant additive or change element at this time, unless you are not using Caterpillar Antifreeze which contains additive.
8. Start the engine and operate it with the radiator cap off, until the thermostat opens and the level stabilizes.
 9. Maintain the coolant level to within 13 mm (.5 in) of the bottom of the fill pipe.
 10. Install the radiator cap.
 11. Stop the engine.